

ELECTROFUSION INSTALLATION AND TRAINING MANUAL



EST.  1976

Distributed by:

GROEBNER | 800-638-8322
POWERED BY EXPERIENCE | www.groebner.com

GEORG FISCHER
PIPING SYSTEMS

Thank you for selecting Georg Fischer Central Plastics' electrofusion products. GFCP strives to deliver the best technology and materials combined with rugged, durable construction to provide a productive and reliable electrofusion connection for your polyethylene system.

To ensure this product lives up to all expectations, it is important to receive proper training from an authorized instructor and to read and comply with this instruction manual before attempting to make any electrofusion joints.

This manual is intended to provide a general introduction to the tools and steps required for making a sound electrofusion joint. The instructions contained in this manual have been qualified to the requirements of Title 49 Code of Federal Regulations, Part 192.283. GFCP assumes no liability in connection with the data contained herein and all data is accepted at the user's risk.

GFCP strongly recommends that electrofusion fittings be installed only by persons that have received training from an authorized instructor, that have a strong working knowledge of polyethylene and heat fusion, and that have demonstrated their understanding of these requirements by making electrofusion joints that have been qualified by destructive testing. Persons responsible for the joining of polyethylene pipe for regulated gas applications must qualify according to the requirements of Title 49 Code of Federal Regulations, Part 192.285. Other regulations may also apply depending on the application, local codes, and/or jurisdictional oversight of state and local regulating agencies.

All rights reserved, in particular the rights of duplication and distribution as well as translation.

Duplication and reproduction in any form (print, photocopy, microfilm or electronic) requires the written permission of Georg Fischer Central Plastics, LLC.

Table of Contents

General Information.....	4
Safety Notes and Warning Symbols	5
Principles of Electrofusion.....	6
Jobsite Preparation	8
Fitting Storage and Handling.....	9
Required Tools	10
Pipe Inspection and Preparation.....	11
Pipe End Cutting.....	12
Pipe Roundness	15
Cleaning and Marking Pipe.....	16
Scraping/Peeling.....	18
Scraping/Peeling Tools	19
Assembly Clamping	20
Cooling	22
Control Box.....	25
Power Requirements.....	26
Fusion Parameters.....	27
Installation Training Procedures	28
Electrofusion Coupling Installation Procedure	28
Electrofusion Saddle Installation Procedure.....	30
Re-Fusion.....	32
Tapping.....	33
Service Tapping Tee:	34
High Volume Tapping Tee:	35
Pressure Testing	37
Operator Training Qualification Guide.....	37
Recommended Training Curriculum	37
Destructive Tests.....	38
Couplings (Sockets).....	38
Saddles (Sidewall)	39
Images of Acceptable and Unacceptable Destructive Test Results.....	42
Electrofusion Fitting Pressure Rating, Testing, and Specifications.....	43

General Information

Electrofusion joining of PE pressure pipe has been a practice utilized around the world since the 1970's. In 1984 Georg Fischer Central Plastics (formerly Central Plastics Company) began manufacturing electrofusion products in the United States for natural gas and other pressure piping applications.

Many international standards exist for electrofusion fittings, testing, and joining equipment. In North America, ASTM standard specification for materials (ASTM D3350), performance (ASTM F1055), and installation practice (ASTM F1290) have been in publication for many years. All GFCP electrofusion fittings are marked to indicate that they meet the material, design, and performance requirements of ASTM F1055 for use in a pressure pipe application. Additional markings indicate that other performance and health effect requirements are satisfied, such as AWWA C906 and NSF 61.

Proper installation techniques, installer understanding of and training to these techniques, and effective examination before installation are all essential keys to a successful electrofusion joint. This document provides detailed instructions for each key step to making a successful installation, explains why each step is important, and describes how to tell if the requirements of each step have been accomplished. The basic steps for a successful electrofusion are included in these instructions. **THERE ARE NO SHORTCUTS TO THESE INSTRUCTIONS.** Failure to follow these instructions and/or failure to satisfy the basic requirements for each step will result in a poor quality fusion.

Safety Notes and Warning Symbols

Safety notes are included in this manual where appropriate, however this manual does not purport to address all of the safety concerns associated with its use. It is the responsibility of the user of this manual to establish appropriate safety and health practices and to determine the applicability of regulatory limitations prior to use.

Symbols are used throughout this manual to indicate the potential for danger, injury, and/or material damage, and to alert the user of important information related to the fusion process. Symbols indicate that particular attention should be given and that an action is necessary.

Symbol	Meaning
	Attention! – Important Information! Possible danger, damage, risk of unsuccessful fusion or poor fusion quality.
	Best Practice – This symbol is used to indicate an instruction that is considered to be a “best practice”. This practice is highly recommended and potentially vital to success.
	Prohibited! – This symbol is used to indicate a practice, material, tool, or action that is specifically prohibited in conjunction with instructions in this manual.

- Electrofusion fittings and equipment are not to be considered “explosion proof”.
- Caution should be exercised when working with generators and other electrical power sources.
- Scraping/peeling tools can have sharp edges. Use with care to avoid injury.
- Tools should be in good working order and inspected before use for wear and/or damage. Damaged or worn tools should not be used until repaired.

Principles of Electrofusion

Polyethylene (PE) Electrofusion fittings are manufactured with a precision-designed resistance wire heating coil mechanism. The wire heating coil is encapsulated by PE and located just below the fitting's fusion surface.

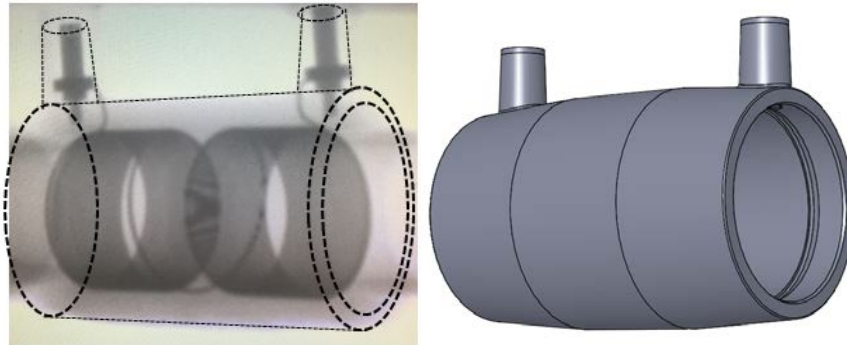

X-ray perspective of heating coil mechanism

The electrofusion process works by introducing a controlled electrical voltage to the heating coil, which in turn generates heat to melt the fitting and pipe surfaces. As the polyethylene surfaces melt they also expand in volume to close any gaps between the pipe and fitting. After the gaps are closed, the continued melt expansion generates pressure within the heated zones.

The expanding melt reaches “cold zones” within the fitting where the leading edges of melt flow cool and solidify, thereby blocking any further melt movement or escape. The heating process continues for a predetermined time so that substantial pressure is reached through continued melt expansion in the contained melt pool of the pipe and fitting surfaces. The molten surfaces under pressure will join at the molecular level. Upon completion of the heating phase, the assembly is held stationary by external clamps as the melted materials begin to immediately cool and co-crystallize into a single homogenous monolithic structure between the pipe and fitting. Once completely cooled, the surfaces are permanently joined together and cannot be separated.

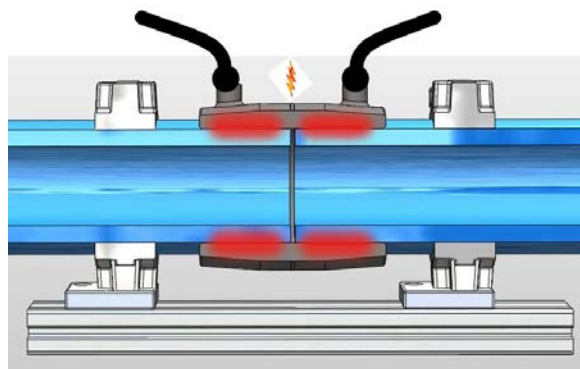
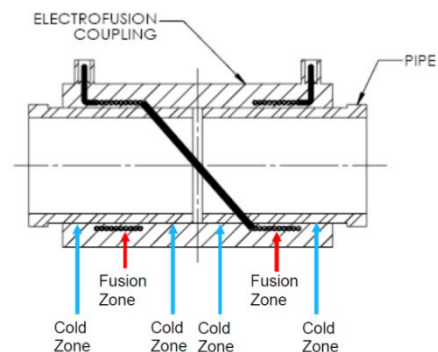

Equally as important as the heating phase of the fusion cycle, the cooling phase is a defined part of the electrofusion process. Because polyethylene is a thermoplastic, the material softens when heated and is therefore vulnerable to stresses from external forces such as the weight of the pipeline and bending forces from pipe curvature or misalignment while it is still hot. Fittings must be held stationary and in alignment by clamps during the fusion and cooling process to protect against inadvertent disturbance of the molten PE until the assembly has cooled and regained its material strength.

Because PE is a very good insulator the cooling time needed can be significantly longer than the original fusion time. As illustrated in the temperature profile shown below, the temperature of the PE remains above the melting point as the heat dissipates and migrates outward toward the pipe and fitting surfaces. In general, the time needed for the material to cool to the point that it has regained adequate strength for rough handling such as bending or backfilling is three times the clamping time listed on the fitting label.

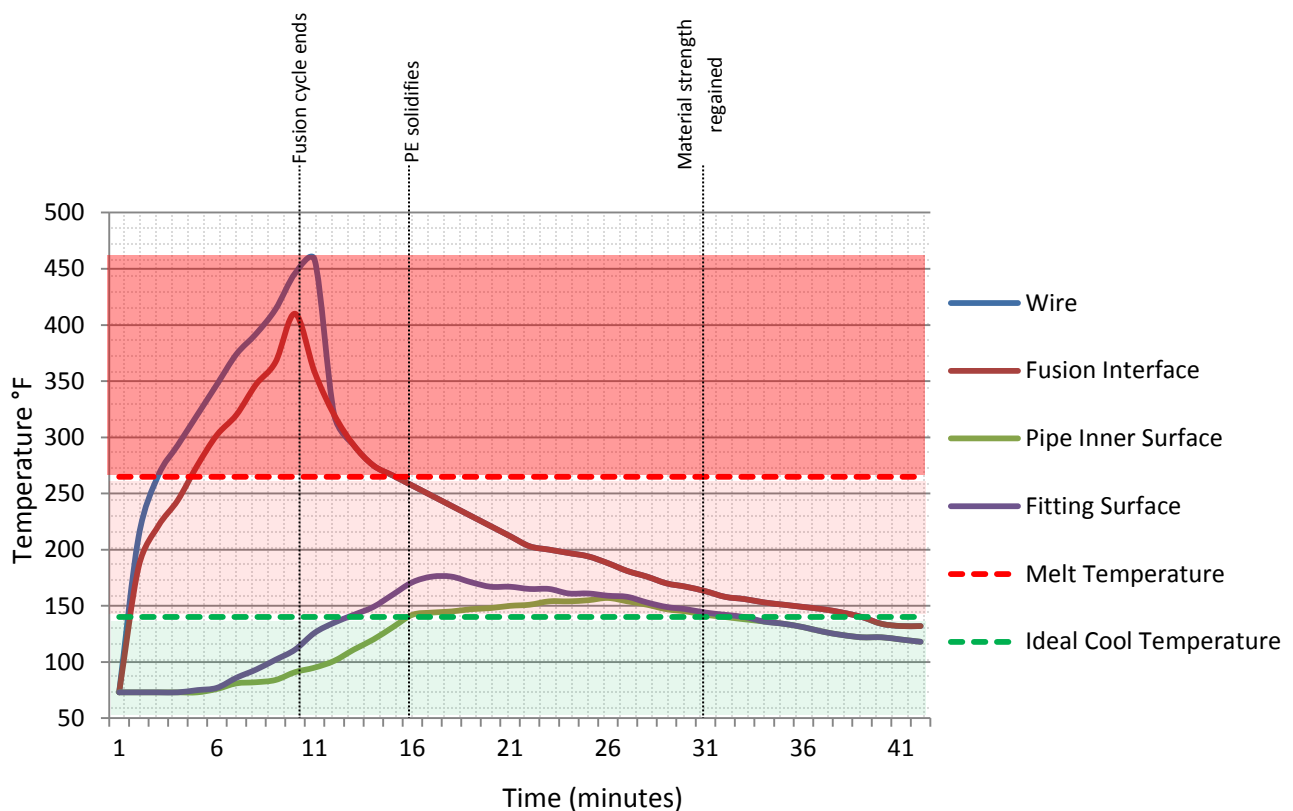

Jobsite Preparation

All heat fusion joining methods require that there is no water flowing or standing in or below the pipe that can reach the fusion surfaces. De-watering of the site may be required to prevent ground water from reaching the fusion and contaminating the surfaces to be joined. Dewatering can be accomplished using portable submersible pumps (Fig.1) in moderate conditions where high water table conditions result in water infiltration to the work area. Water flowing through pipes for saddle/sidewall fusions is acceptable when contained inside the pipe so that it cannot reach the fusion surface.

Standing water in the work area may be unavoidable and acceptable, however at no time should it reach the prepared fusion surfaces or pipe and fitting assembly during the fusion process.



Figure 1 Submersible pump

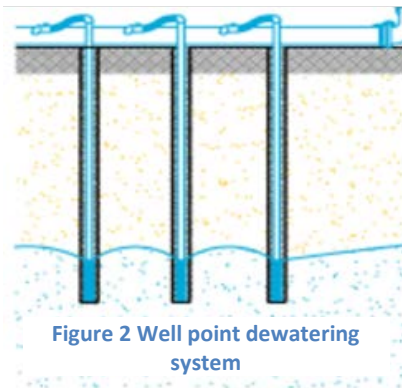

Figure 2 Well point dewatering system

In more aggressive groundwater conditions, a well point dewatering system may be necessary. Dewatering can also be accomplished by installing shallow siphons (Fig. 2) two to four feet below grade in larger excavations for areas with high ground water content and continuous inflow and infiltration.

Pipe surfaces must be dry during fusion and should be protected from moisture in heavy rain or snow events by covering the work area with a tent or canvas awning. Humidity and wind, excluding blowing particles, is not a concern that needs to be considered.

In repair or cut-in situations for water piping, flowing water in the pipe may be present due to leakage of valves. Flowing water in contact with the fusion surfaces during the assembly or fusion cycle must be avoided as it can contaminate and hinder the fusion process and/or cause voids and pockets in the fusion surfaces as the moisture turns into expanding steam during the fusion process. Some practical temporary methods for accomplishing this while avoiding the need to disinfect the line afterwards are the use of organic absorbent materials, such as bread, which can later be flushed from the system at downstream hydrants. Dry ice placed in the pipe upstream of the fusion location will temporarily freeze small amounts of flowing water until the fusion process can be completed. In smaller diameter water pipes inflated latex balloons also provide good temporary stoppage of trickling water. The balloon will burst during pressure testing and can be flushed from the system at a downstream outlet.

GFCP electrofusion fittings can be installed at ambient temperatures ranging from -10°F (-23°C) to 120°F (49°C) without change to the fusion procedure. The fusion machine monitors ambient temperature and will not allow a fusion to begin if the temperature is beyond this range. If fusing in temperatures below -10°F a site shelter should be erected and heated to at least -10°F.

Fitting Storage and Handling

Electrofusion fittings are packaged in sealed plastic bags as protection against accumulation of dust, dirt, and contamination. The bag should remain in place during normal handling and should only be removed at the time of installation. Bags are not airtight, and in many cases have holes made to allow trapped air to escape. Small dust particles or moisture from humidity may enter the bag and can be removed from the fitting with isopropyl alcohol at the time of installation. Electrofusion fittings are also packaged in boxes to protect against other sources of degradation, such as oxidation due to UV exposure over long periods of storage.



Fittings should always be stored indoors, in their original packaging, until the time of installation.

Black electrofusion fitting resin contains a 2% to 3% carbon black additive to protect against UV degradation effects. Yellow electrofusion fitting resin contains a stabilization pack that also provides some degree of protection against UV effects. Fittings stored indoors in their original packaging have a virtually unlimited shelf life.



Fittings with an unknown storage history or that have been exposed to questionable storage conditions should be evaluated through destructive testing of sample fusions prior to use. If fusion quality is shown to be affected, the fittings in question should be discarded and should not be installed.

Fittings should be inspected for damage before installing to ensure that connection points such as terminal pins have not been damaged from handling, that there is no visible damage to fusion surfaces or heating wires, and that no foreign materials are present on or near the fusion surfaces.

Fittings can be cleaned if incidental contact is made with the fusion surface. A suitable cleaning agent that contains no additives to hinder the fusion process must be used. 90% or greater concentration of Isopropyl alcohol¹ with no additional additives except water is universally accepted as a good cleaning agent. Care should be taken that any wipes or cloths used to clean the fitting have not been used prior as contaminates that can interfere with the process may be accidentally introduced.

- Acetone has been found to be an acceptable alternative cleaning agent in situations where isopropyl alcohol use may be restricted. Purity of the acetone should be investigated by making test fusions with the cleaning agent prior to use to ensure there are no other additives that may interfere with or prevent the fusion process.
- DO NOT USE DENATURED ALCOHOL – Denatured alcohols may contain additives that can prevent fusion and shall not be used.**

A “clean” fitting has no visible debris or particles on the fusion surface. It has no body oils or other substances that will prevent PE from fusion joining. It is not necessary that fittings are sterile to perform as intended but some compounds that are not visible to the eye can prevent fusion. Electrofusion fittings have fusion zones of relatively large surface area when compared to a pipe end cross-sectional area, so while a small dust particle or droplet of water will not create a point of failure, clean fittings and a properly prepared pipe surface are essential to ensure successful fusion every time.

Required Tools

Proper tools are essential for a successful electrofusion installation. Tools include devices for measuring, marking, cutting, scraping/peeling, cleaning, clamping (which includes aligning and securing), re-rounding, and power delivery. At minimum, the following items should be accessible during installation:

Measuring: A tape measure or ruler is helpful for measurement of insertion (stab) depth of pipe ends inside a coupling and checking pipe for roundness. A circumferential wrap Pi tape for measurement of pipe diameter is also useful.

Marking: A permanent marker should be visible on the pipe color being used. For black pipe, a silver colored Sharpie®, or equivalent, permanent marker works well. The marker dries fast and contains no oils or other ingredients that could accidentally contaminate a prepared pipe surface. Marks are needed to locate insertion depths and to use as a guide for pipe scraping effectiveness.

Cutting: Devices that deliver a relatively clean and square cut (± 5 degrees) on the pipe ends are recommended. Many suitable types of pipe cutters are commercially available that can be used for diameters of 12 inch and smaller. (See Pipe Preparation section)

Cleaning: Clean water can be used to remove mud and dirt from the pipe before scraping. 90% or greater concentration of isopropyl alcohol is needed for cleaning fittings or pipe surfaces after it has been scraped/peeled.¹ Pre-packaged alcohol wipes or bottled alcohol with clean, non-dyed, low-lint wipes or cloths are acceptable. Do not use detergents or soaps to clean the pipe.

Scraping/Peeling: Scraping and peeling tools remove the oxidation and contamination layer from the pipe. “Peeler” type tools designed specifically for electrofusion pipe preparation are strongly recommended. Approved scrapers/peelers are tools that have been tested and are acceptable for use, however not all scraping tools are equal, and some require more operator skill and diligence than others. (See Pipe Preparation section) The user should be familiar with the tools being used and should qualify fusions using those tools.

Clamping:

- Clamps are needed to align pipe ends and restrain stresses inside the coupling and pipe assembly.
- Clamps for saddle fusion are always required. Some saddle fittings use an integrated clamp such as a strap or plastic underpart that is supplied with the fitting and remains in place after fusion. Some saddles use a re-usable mechanical clamp that is designed for that particular size and style of fitting. (See Assembly Clamping section)

Power Source: An AC electrical source is required to power the electrofusion control box. Control box inputs are either 115v or 230v input depending on the model. The power should be of sufficient output for the size and type of fitting being fused. (See Power Requirements section and Table 4)

Extension cords: Extension cords can be used, however they should be of sufficient gauge and not more than specified for the maximum length. (See Power Requirements section and Table 4)

¹ Previous versions of GF installation manuals included a minimum of 70% isopropyl alcohol with no additional additives except water. 70% isopropyl alcohol was accepted as the minimum concentration because it was historically more commonly available than higher concentrations. The use of 70% isopropyl alcohol as an alternate will not affect the fusion joint quality and has been extensively qualified, however it may not be as effective as a cleaning agent as higher concentrations and can take longer to dry in colder climate conditions.

Pipe Inspection and Preparation

Ensure that the pipe to be fused is the correct size for the electrofusion fitting being used. Pressure pipe is manufactured to a standard dimension with allowable tolerances for minimum and maximum diameter. Electrofusion fittings are designed for use on pipes made to those standard diameters in dimensions for Iron Pipe Size (IPS), Copper Tube Size (CTS), and Ductile Iron Pipe Size (DIPS). Pipe that is outside of the diameter tolerance band of the appropriate pipe standard should not be used. Pipe SDR/DR ranges from 9 to 17 are suitable for use with electrofusion fittings without change to the fusion procedure. Contact GFCP for applications with thinner pipe walls. Use Table 1 for reference when measuring pipe diameter to ensure that pipe or tubing is within diameter tolerance.

IRON PIPE SIZE (IPS) ASTM D3035/F714			COPPER TUBE SIZE (CTS) ASTM D2737		
PIPE SIZE	Nominal Diameter (inches)	Tolerance (±)	TUBING SIZE	Nominal Diameter (inches)	Tolerance (±)
1/2 IPS	0.840	0.004	1/2 CTS	0.625	0.004
3/4 IPS	1.050	0.004	3/4 CTS	0.875	0.004
1 IPS	1.315	0.005	1 CTS	1.125	0.005
1 1/4 IPS	1.660	0.005	1 1/4 CTS	1.375	0.005
1 1/2 IPS	1.900	0.006	1 1/2 CTS	1.625	0.006
2 IPS	2.375	0.006	2 CTS	2.125	0.006
3 IPS	3.500	0.016			
4 IPS	4.500	0.020			
6 IPS	6.625	0.030			
8 IPS	8.625	0.039			
10 IPS	10.750	0.048			
12 IPS	12.750	0.057			

DUCTILE IRON PIPE SIZE (DIPS) ASTM F714		
PIPE SIZE	Nominal Diameter (inches)	Tolerance (±)
3 DIPS	3.960	0.018
4 DIPS	4.800	0.022
6 DIPS	6.900	0.031
8 DIPS	9.050	0.041
10 DIPS	11.100	0.050
12 DIPS	13.200	0.059

Table 1 - Pipe Diameter tables

Pipe End Cutting

Proper insertion depth of a pipe end into an electrofusion coupling is required for a successful fusion. Failure to insert the pipe end correctly can result in a loss of melt containment during the fusion process.

Melt containment and the resulting melt pressure that is generated through thermal expansion is a critical component to the fusion process. As seen on the image to the right, heating coils in fusion zones on either side of the coupling are separated by three areas known as “cold zones” where no heat is generated. The expanding melt in fusion zones reaches these cold zones and cools until the movement stops, thereby blocking the escape of any further melt. As the fusion process continues, a considerable amount of melt pressure is generated within the fusion zones. This pressure is necessary to provide adequate contact between the melted pipe and coupling surfaces for co-mingling and fusion.

A pipe end that is not inserted beyond the innermost heating wire is commonly referred to as being “short-stabbed” and is the result of an assembly error.

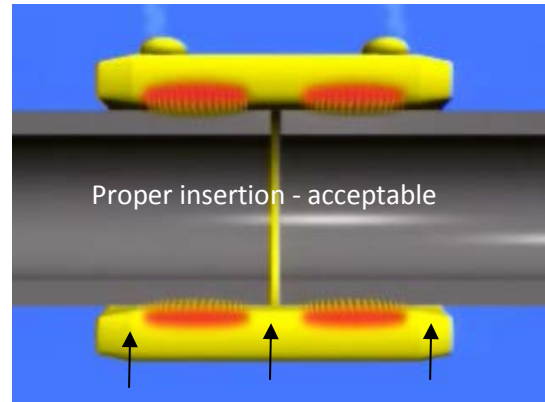

Cold zones

Short Stab – Incorrect Assembly: Assembly errors that can occur include “short-stab” conditions where the one or both of the pipe ends are not centered in the coupling. This condition is avoidable by measuring and marking the stab depth on the pipe ends before inserting them into the coupling. If the pipe ends are not properly inserted, the melt generated during the fusion cycle will expand and flow over the end of the exposed pipe inside the fusion zone. Heating coil wires are carried by the uncontained melt flow, causing shorting and rapid overheating of the fusion zones.

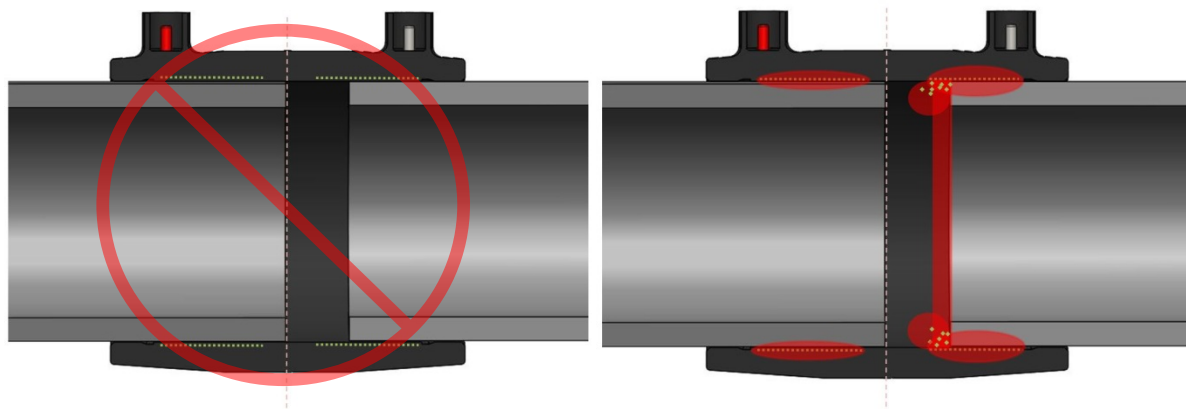

Short Stab - Incorrect Assembly

Mis-Stab – Incorrect Assembly: A mis-stab is another avoidable assembly error where the pipes are not located in the center cold zone of the coupling. In this case, one pipe end is over-inserted into the coupling, while the other is under-inserted. Melt again is allowed to escape between the pipe ends and the potential for heating coil shorting is likely.

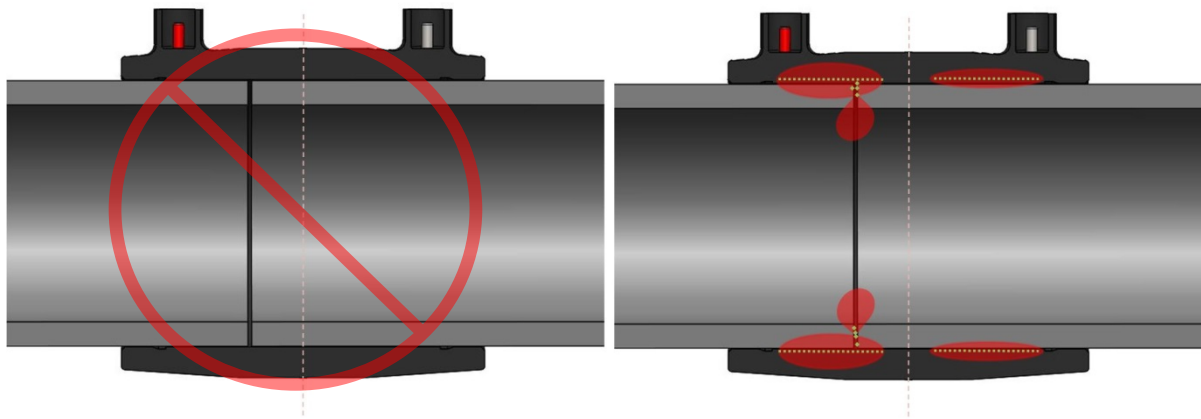

Mis-Stab - Incorrect Assembly

Another potential error that can cause loss of melt containment is the lack of a square cut on the pipe ends. While it is not necessary, nor practical, that the pipe ends must be cut to exactly 90 degrees, care should be taken to keep the cut as square as possible. Cold zone lengths are designed to accommodate some degree of mis-cut on the pipe ends and still ensure full coverage of the heating wires and sufficient cold zone contact to contain melt flow. A condition where the pipe end is cut at too great an angle to allow the pipe end to cover the heating coil and cold zone is referred to as a “mis-cut” assembly.

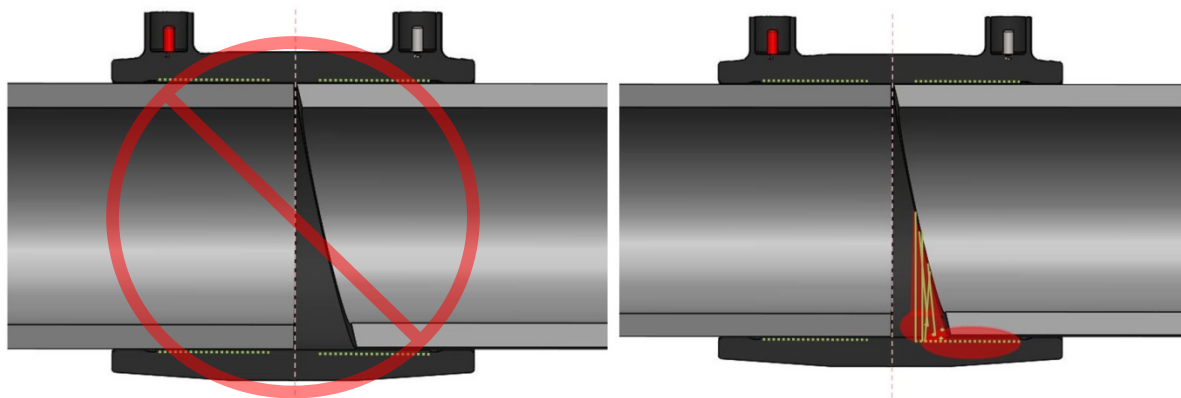

Mis-Cut - Incorrect Assembly

Pipe End Cutting Procedure: To ensure that the pipe ends can be correctly inserted into the center of the electrofusion coupling, do the following:

1. Cut the pipe ends as evenly and squarely as possible. For smaller pipe or tubing sizes, cutters made for this purpose work well.



For larger pipe sizes that are cut by hand, make a guide mark around the pipe that can be followed with the cutting tool. To accomplish this, a wrap-around strap can be used to ensure a straight mark. Chainsaws or reciprocating saws may be necessary for large diameter pipes. If using a chainsaw, do not use chain oil.



2. If a square cut cannot be achieved, ensure that the resulting gap between the pipe and the square when measured with a square placed on the pipe end at its maximum width is equal to or less than what is shown in Table 2.

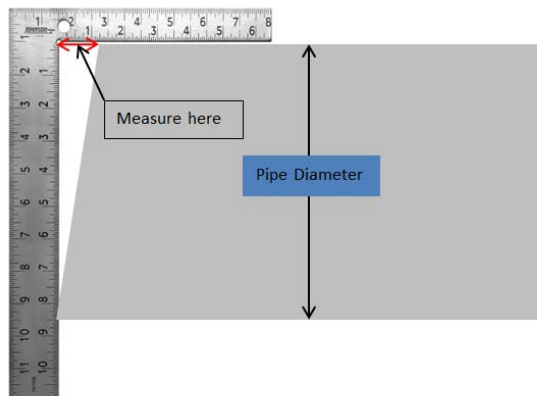

Pipe Size	Maximum gap
½ CTS to 1 ½ IPS	1/8"
2 IPS	3/16"
3 IPS	5/16"
4 IPS	5/16"
6 IPS	1/2"
8 IPS	3/4"
10 IPS	7/8"
12 IPS	1"

Table 2 – Pipe Cut Angle

Pipe Roundness

Polyethylene is a flexible material. Storage, coiling, stacking, soil load, and even processing can affect its “roundness”. Pipe roundness is an important factor to be considered when making fusion joints. With electrofusion joints, roundness can affect the annular space, or gap, between the pipe surface and coupling or saddle inside diameter. Electrofusion works through volumetric expansion of the polyethylene material as it is melted to close gaps. An excessive gap, that is more than the melt expansion can close, will result in a lower fusion pressure inside the coupling and possibly a weakened joint strength. Melt expulsion at the end of the coupling can also occur. Most often, 2 IPS and smaller diameter tubing is flexible enough that the coupling and alignment clamps will provide the necessary rounding forces and no other re-rounding device is needed. For sizes larger than 3 IPS, the following steps can be taken to ensure that does not occur:

The condition of pipe roundness can be expressed in two ways: “out-of-roundness” or “ovality”. While both are referencing the same basic condition, it can sometimes be confusing.

- Out-of-roundness is the difference in the maximum measured diameter minus the minimum measured diameter. The pipe can be measured with a tape measure or caliper to find the maximum (d1) and minimum (d2) diameter points. The out-of-roundness is calculated as $d1 - d2$ as measured in the field.

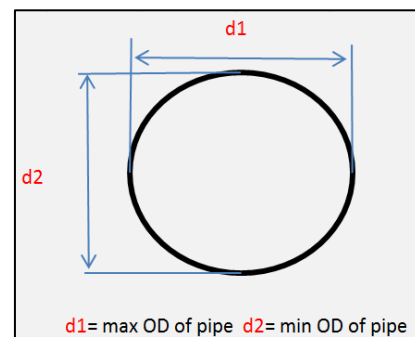

Figure 3 - Diameter measurement diagram

- Ovality is the difference between the maximum and minimum measured outside diameters expressed as a percentage. Ovality is calculated as $(d1 - d2) / D_{average} \times 100$.

For sizes equal to or larger than 3” IPS, re-rounding clamps may be needed on either side of an electrofusion fitting to ensure that the gap between the pipe and fitting is not too large. Table 3 can be used for guidance when measured pipe roundness conditions are approaching the condition where re-rounding clamps may be needed. Re-rounding of the pipe should bring the measured difference between d1 and d2 to equal or less than the measurement shown in the table.

Maximum Out-Of-Roundness	
PIPE SIZE	d1 - d2
3"	.125 or 1/8"
4"	.125 or 1/8"
6"	.187 or 3/16"
8"	.187 or 3/16"
10"	.250 or 1/4"
12"	.250 or 1/4"

Table 3 - Out of Roundness limits

Pipe surface damage: Installation of pipe can cause surface scratches or gouges. Smaller scratches from dragging or normal handling are not problematic and will normally be removed during the pipe preparation process by scraping or peeling.

- ⚠ Gouges on the pipe surface that are deeper than the scrape/peel depth may also require extra attention when scraping the pipe to ensure that any debris or contaminates embedded in the gouges are removed.
- ⊘ If the gouge exceeds 10% of the pipe wall thickness that pipe section should be cut out and replaced to maintain the maximum pressure rating of the pipe.

Cleaning and Marking Pipe

During the initial pipe inspection and prior to scraping, the pipe can be cleaned of mud and debris with clean water. Use no detergents as wetting agents and other substances contained in detergents can be difficult to remove from the pipe and will interfere with the fusion process later. If oils are suspected to be on the pipe surface at this point, additional cleaning with 90% or greater isopropyl alcohol may be necessary.

- ⚠ Pipe that has been installed by directional boring where drilling lubricants such as bentonite have been used require particular attention to pre-cleaning before scraping as well as any cleaning after scraping. Drilling lubricants, even when dried, can be difficult to see and are easily spread by wiping. Use extra caution to only wipe over areas that were previously cleaned with isopropyl alcohol to prevent spreading onto prepared surfaces.
- ⚠ Inspect the pipe surface to be scraped/peeled for embedded foreign objects such as rocks that might damage scraping tool blades.
- 🚫 **Do not use detergents to clean the pipe.**

✔ Procedure: Clean an area larger than the area to be scraped/peeled and fused:

1. Mark the initially cleaned area.

- a. For saddles, initially clean (with water), dry, and mark an area that is approximately 3 times wider than the area to be peeled/scraped. **DO NOT WIPE OUTSIDE THIS INITIALLY CLEANED AREA IN LATER STEPS.**

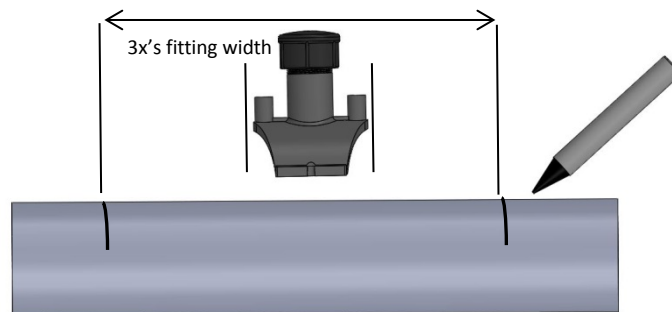

- b. For couplings, initially clean (with water), dry, and mark an area that is at least 2 times the full length of the coupling on each pipe end. **DO NOT WIPE OUTSIDE THIS INITIALLY CLEANED AREA IN LATER STEPS.**

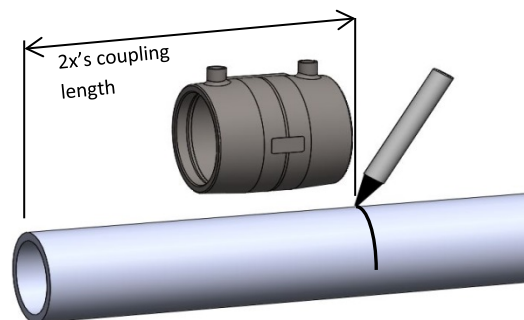

This will remove loose particles and mud and will establish the area that should not be exceeded when cleaning in later steps. Additional cleaning of this area with Isopropyl alcohol is good practice to help remove other potential contaminants such as drilling fluids that may not be removed by cleaning with water. Do not exceed the marked limits of the cleaned area when wiping beyond the mark with alcohol.²

² Note: The marking of this initially cleaned area is to indicate the limits of the cleaned surface so that subsequent cleaning with wipes does not cross over onto un-cleaned pipe surfaces, thus picking up unintended contamination that could be redistributed over a previously cleaned surface.

2. Mark a second area inside the initially cleaned area that is slightly longer than the area to be scraped/peeled. Clean the 2nd marked area again with isopropyl alcohol prior to scraping, being careful not to remove the marking. **Discard the cloth/wipe after cleaning and do not re-use.**

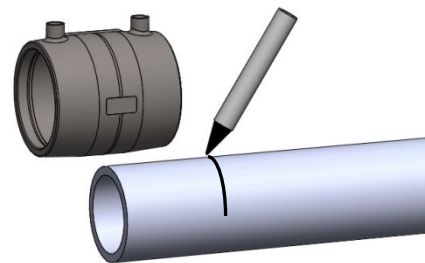

3. Scribe the pipe surface at regular intervals or mark in a criss-cross pattern, so that any areas missed by the scraping tool will be visible by the marks that still remain.



4. Allow marks to dry before scraping/peeling the pipe and make sure that the scraping tool does not contact pipe that has not been cleaned previously. Avoid allowing shavings/peeler tailings produced by the peeler from winding around pipe as this can re-distribute contaminants that may not have been removed by the initial cleaning. Break the tailings away frequently as-needed.

- ✔ A best practice is to physically scribe a scraping depth indicator mark, or witness mark, onto the pipe surface at intervals around the pipe that will assure that the entire circumference was adequately scraped/peeled. This mark scribes the pipe surface to the depth of at least .006" while not removing more than 10% of the pipe wall thickness. Removal of the minimum amount of .007" when scraping/peeling will remove the scribe mark and provide visual confirmation that adequate pipe surface has been removed by scraping.



- ✔ When using peeling type scraping tools the ribbon being peeled from the pipe can also be measured to gauge the scraper's effectiveness. Using an approved and qualified peeling tool, peel the pipe to remove at least .007" of the outer surface. This depth removes the oxidation layer from the pipe, along with surface contaminants that will prevent fusion.



- ⚠ Witness/permanent marks should be completely dry before scraping.
- ⚠ Witness marks should be completely removed by scraping.
- ⚠ Indented pipe print lines should be completely removed by scraping.
- ⚠ Scribed depth marks should be completely removed by scraping.

Scraping/Peeling

Scraping/peeling is perhaps the most important and least understood aspect of making a sound electrofusion joint. Improper pipe preparation is overwhelmingly the leading cause of unsuccessful electrofusion joint attempts because the installer may not completely understand the goal of pipe scraping, which is to remove a thin layer of the outer pipe surface to expose clean virgin material beneath.

⚠ THIS STEP IS VITALLY IMPORTANT TO SUCCESSFUL FUSION JOINTS!!!! CAREFUL ATTENTION MUST BE GIVEN TO PIPE PREPARATION AND SCRAPING!!!!

Pipe surfaces can undergo surface oxidation from the extrusion process, transportation, handling, and outdoor UV exposure. Surface oxidation is a normal chemical reaction that results in a physical change to the molecular structure of the polymer chains on the pipe surface. Oxidation acts as a physical barrier, and therefore those surfaces cannot be heat fused. Oxidation cannot be wiped away with any cleaner. Simply roughing or scratching the pipe surface is not sufficient. In order to achieve fusion this oxidized layer must be *removed*. Even new pipe can have surface contamination and must be properly scraped/peeled before a fusion will be successful.

Certain contaminants such as hydrocarbons and very fine particulates such as those contained in drilling fluids may not be easily removed by cleaning, may not be readily visible on the pipe surface, and can only be removed by scraping/peeling.

The outer oxidation layer on a pipe surface is very thin. It does not increase in depth more than a few thousandths of an inch even over long periods of outdoor exposure, so regardless of the amount of time the pipe has been stored before scraping, the scraping depth requirement is the same. An adequate minimum amount of material that must be removed is just seven one-thousandths of an inch (.007"). That thickness is approximately the same as two sheets of ordinary paper.

Always use witness marks to help identify un-scraped pipe surface areas. **Allow marks to dry completely before scraping.** As described in the marking section use a permanent marker of a color that is visible on the pipe to mark the location of the fitting on the pipe. This mark indicates the pipe surface that will be scraped/peeled to remove contamination and oxidation. As a visual indicator, it is recommended to mark the entire fitting location or the circumference of the pipe with lines in a horizontal and vertical criss-cross pattern. These "witness" marks serve as visual indicators while scraping because any marks that are still visible on the pipe after scraping are evidence that little or no pipe surface material was removed by scraping. The photograph to the right shows an example of a poorly scraped/peeled pipe surface with surface marks still visible.



Poor scrape - markings not removed

Scraping/Peeling Tools

Tools that are approved for scraping pipe for electrofusion joining are those that remove material cleanly. “Peeler” type tools that remove a continuous and measureable ribbon of pipe surface are the preferred scraping tools and should be used whenever possible. The advantages of these tools are:

- ✔ The ribbon thickness can be measured to verify that the tool is performing as designed.
- ✔ A continuous ribbon ensures that the entire circumference of the pipe is being peeled.
- ✔ Any skipped or missed paths between peeler revolutions are easily identified using only lengthwise scribed witness marks.

NOTE: Hand tools such as paint scrapers and scrapers with serrated blades have historically been used with good success, and they can be used effectively however as a best practice, they should only be used in situations where confined working space or pipe scratches or gouges require a hand tool. It must be recognized by the user that they require more effort and diligence to ensure the entire area is being scraped. Significant operator experience is needed in order to know that adequate pipe surface material has been removed when using a hand scraper.

The majority of failed fusions can be attributed to improper or inadequate pipe scraping. The use of hand tools should be avoided when peelers are commercially available for the fitting being installed.³

Regardless of the tools being used, it is important that they are in good working order, and free of greases or other potential contaminants that can be spread onto the pipe surface. Inspection of installation tools to ensure they are working properly is recommended before each use. Peeler blades should be free of damage such as knicks. Damaged or dull blades that do not peel the pipe should be replaced. Check rollers and guides of tools that do not advance along pipe properly. There should be no missed or skipped areas on the pipe when using a peeler tool.



- ❌ **Sandpaper, utility/emery cloth, wood rasps and metal files are never allowed and will result in failed fusions.**
- ❌ **Abrasives/grinders are never allowed and will result in failed fusions.**

³ The use of a hand scraper tool is not prohibited; however it should be emphasized that improper use and inconsistent performance of hand scrapers are the leading cause of installation errors and poor joint performance and therefore the use of hand scrapers is discouraged whenever possible.

Assembly Clamping

Assembly clamps are always required for saddle fusions to hold the fitting to the pipe using the correct amount of pressure in right places. Assembly clamps for couplings are also necessary to ensure that the area of the fusion is not subject to bending, binding, or movement. Under ideal conditions a coupling may even feel loose between the clamps on the pipe before fusion. Assembly clamps also offer protection from accidental movement during the cooling cycle that will disturb the joint. Assembly clamps can also provide the added benefit of re-rounding pipe ends. The primary goal is to ensure that the pipe and fitting assembly are stable, free of external stresses, and immobile until the cooling time has been achieved.

Clamping of Couplings: Clamps for couplings and reducers are designed to align and restrain the pipe ends on either side of the coupling. The coupling itself is not clamped and is free between the clamps:

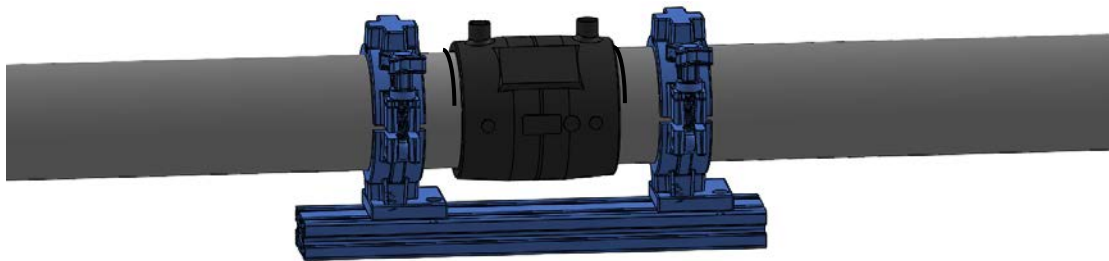

Clamping of Saddles: Clamps are always required when fusing saddles. The clamps provide the necessary attachment to the pipe and resist melt expansion forces to achieve the intended melt pressure on the pipe. Saddle clamps may be an external mechanical clamp that is re-usable or an integrated and permanent bolt-on clamp or strap. An underclamp (or strap) is a clamp that “pulls” the fitting base onto the pipe. A top loading clamp “pushes” the fitting downward onto the pipe. Each saddle fitting has a specific clamp(s) that has been designed and qualified for use. Substitutions are not acceptable and may result in failed fusion attempts.

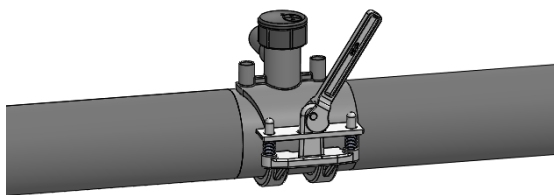

Mechanical re-usable clamp



Permanent bolt-on underpart or understrap

Ensure that mechanical clamp placement is centered on the fitting and that underparts are bolted correctly to avoid uneven clamping.

- ⊘ External forces from service lines, valves, and or heavy appurtenances must be blocked or supported during fusion and cooling of saddle fittings.

- ⚠️ Avoid connecting the service line to the outlet before fusing the saddle to the main when possible. If the outlet/service connection is made to the saddle fitting before the saddle is fused to the main always ensure that the pipe connected to the tubing does not exert any pulling, twisting, or sideways forces on the main. Use shoring/supports as shown below to prevent external forces if necessary:

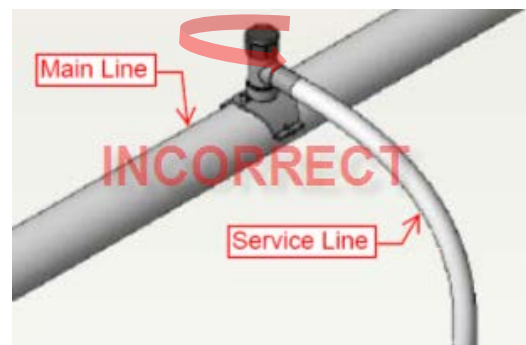
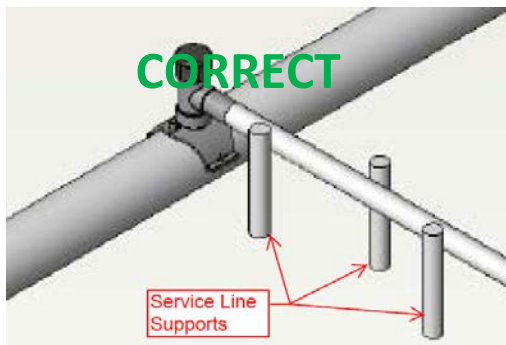

- ⊘ Never attempt to fuse a saddle to the main by holding the fitting by hand.
- ⊘ Never use a clamp made for another brand or type of saddle on a GFCP saddle.
- ⊘ Never use hose clamps, ratchet straps, or other fasteners that are not qualified or intended for use with the saddle design.
- ⊘ Never allow the weight of pipe, valves, or appurtenances to be supported only by the saddle.

Supports: If cribbing or pipe stands are used to support the pipeline while an electrofusion joint is being made, ensure that the supports are placed on both sides so that no weight is being supported by the electrofusion fitting and that no bending stress is exerted on the joint area. See below for correct and incorrect support placement:

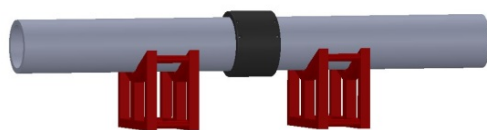

Correct support placement

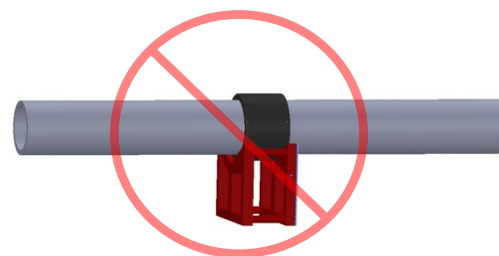

Incorrect support placement

Cooling

Proper observation of cooling time is important. During the heating phase of the fusion process the PE material of the pipe and fitting is heated to melting in order to allow co-mingling of the molecular structures. As the materials cool and co-crystallize into a solid state again the structures cannot be disturbed. PE is a thermoplastic that softens when heated and does not regain its full strength until cooled.

Cooling time is typically expressed by three different terms in the following tables for fusion and cooling times:

1. **Clamped cooling time:** The minimum time the fitting must remain clamped after the fusion cycle is complete. This is the time displayed by the control box.
2. **Time before pressure test & tapping:** The minimum time before the joint can be pressurized to 150% of MOAP and the main can be tapped.
3. **Time before rough handling:** The minimum time before the joint can be subjected to forces such as pulling, lifting, or back filling.

Tapping Tees are listed by saddle size. Times will apply to all outlet sizes.	Connection Pin Size	Fusion Time (Seconds)	Cooling Time in Clamped Position (minutes)	Total Cooling Time Before Pressure/Tap (minutes)	Total Cooling Time Before Rough Handling (minutes)
Tapping Tees:					
1-1/4"	4.7 R	45	10	20	30
1-1/2" IPS	4.7 R	50	10	20	30
2" IPS	4.7 R	90	10	20	30
2" CTS	4.7 R	60	10	20	30
3" IPS	4.7 R	90	10	20	30
4" IPS / DIPS	4.7 R	90	10	20	30
6" IPS / DIPS	4.7 R	90	10	20	30
8" - 10" IPS / DIPS	4.7 R	60	10	20	30

	Connection Pin Size	Fusion Time (Seconds)	Cooling Time in Clamped Position (minutes)	Total Cooling Time Before Pressure/Tap (minutes)	Total Cooling Time Before Rough Handling (minutes)
Reducers:					
3/4" x 1/2" CTS	4.7 R	20	5	15	30
1" x 1/2" CTS	4.7 R	25	5	15	30
1" x 1/2"	4.7 R	30	5	15	30
1" x 3/4"	4.7 R	30	5	15	30
1"x 1" CTS	4.7 R	30	5	15	30
1"x 1-1/4" CTS	4.7 R	30	5	15	30
1"x1-1/4"	4.7 R	45	10	20	30
2" x 1 1/4 IPS	4.7 R	45	10	20	30

Couplings:	Connection Pin Size	Fusion Time (Seconds)	Cooling Time in Clamped Position (minutes)	Total Cooling Time Before Pressure/Tap (minutes)	Total Cooling Time Before Rough Handling (minutes)
1/2 CTS	4.7 R	20	5	15	30
1/2 IPS	4.7 R	20	5	15	30
3/4 CTS	4.7 R	25	5	15	30
3/4 IPS	4.7 R	35	5	15	30
1 CTS	4.7 R	40	5	15	30
1 IPS	4.7 R	45	10	15	30
1 1/4 CTS	4.7 R	50	10	20	30
1 1/4 IPS	4.7 R	75	10	20	30
1 1/2 IPS	4.7 R	60	10	20	30
2 CTS	4.7 S	40	5	20	30
2 IPS	4.7 R	60	10	20	30
3 IPS	4.7 R	180	15	30	35
4 IPS	4.7 R	200	15	30	35
4 DIPS	4.7 S	200	15	30	35
6 IPS SDR 11	4.7 R	500	20	40	45
6 IPS SDR 21	4.7 R	360	20	40	45
6 DIPS	4.7 S	500	20	40	45
8 IPS	4.7 R	500	20	40	45
8 DIPS	4.7 S	500	20	40	45
10 IPS FM 150	4.7 R	750	30	60	60
10 IPS FM 200	4.7 S	TC**	45	60	60
10 DIPS	4.7 S	TC**	30	60	60
12 IPS FM 150	4.7 R	900	30	60	60
12 IPS FM 200	4.7 S	TC**	45	60	60
12 DIPS	4.7 S	TC**	45	60	60

** These fittings require temperature compensation - use barcode

HV Tapping Tees, Branch Saddles with 2" and 1 1/4 Outlets and Transition Saddles with Threaded Outlets	Connection	Fusion Time (Seconds)	Cooling Time in Clamped Position (minutes)	Total Cooling Time Before Pressure Test / Tap (minutes)	Total Cooling Time Before Rough Handling (minutes)
2"	4.7 R	90	10	25	30
3"	4.7 R	60	10	25	30
4"	4.7 R	60	10	25	30
6"	4.7 R	60	10	25	30
8" IPS PE 2406	4.7 R	80	10	25	30
8" IPS PE 3408/4710	4.7 R	240	20	30	40
8" IPS/DIPS	4.7 S	240	20	30	40
10" IPS/DIPS	4.7 S	240	20	30	40
12" IPS/DIPS	4.7 S	240	20	30	40

Branch Saddle IPS	Connection Pin Size	Fusion Time (Seconds)	Cooling Time in Clamped Position (minutes)	Total Cooling Time Before Pressure/Tap (minutes)	Total Cooling Time Before Rough Handling (minutes)
4" x 4"	4.7 R	50	10	20	30
6" x 4" PE 2406	4.7 R	150	15	30	45
6" x 4" PE 3408 / PE 4710	4.7 R	200	15	30	45
8" IPS x 4" IPS	4.7S	TC**	20	40	60
8" IPS x 6" IPS	4.7S	TC**	20	40	60
10" IPS x 4" IPS	4.7S	TC**	20	40	60
10" IPS x 6" IPS	4.7S	TC**	20	40	60
10" IPS x 8" IPS	4.7S	TC**	20	40	60
12" IPS x 4" IPS	4.7S	TC**	20	40	60
12" IPS x 6" IPS	4.7S	TC**	20	40	60
12" IPS x 8" IPS	4.7S	TC**	20	40	60

** These fittings require temperature compensation - use barcode

EF Tee	Connection Pin Size	Fusion Time (Seconds)	Cooling Time in Clamped Position (minutes)	Total Cooling Time Before Pressure/Tap (minutes)	Total Cooling Time Before Rough Handling (minutes)
3/4 IPS	4.7R	30	5	20	30
1 IPS	4.7R	30	10	20	30
2 IPS (EF Adapted)	4.7S	45 (20v)	5	20	30

EF Elbow	Connection Pin Size	Fusion Time (Seconds)	Cooling Time in Clamped Position (minutes)	Total Cooling Time Before Pressure/Tap (minutes)	Total Cooling Time Before Rough Handling (minutes)
2 IPS (EF Adapted)	4.7S	45 (20v)	5	20	30

Branch Saddle DIPS	Connection Pin Size	Fusion Time (Seconds)	Cooling Time in Clamped Position (minutes)	Total Cooling Time Before Pressure/Tap (minutes)	Total Cooling Time Before Rough Handling (minutes)
8 x 4	4.7S	TC**	20	40	60
8 x 6	4.7S	TC**	20	40	60
10 x 4	4.7S	TC**	20	40	60
10 x 6	4.7S	TC**	20	40	60
12 x 4	4.7S	TC**	20	40	60
12 x 6	4.7S	TC**	20	40	60

** These fittings require temperature compensation - use barcode

Table 4 - Fusion and Cooling Time

Control Box

Electrofusion control boxes, also referred to as “processors”, perform vital functions during the fusion process. The control box provides carefully regulated voltage for the required fusion cycle time resulting in the correct amount of energy being supplied to the fitting. During the fusion process, the control box also monitors the power being supplied to the fitting and can detect power supply fluctuations and certain assembly or fitting errors such as disconnected or shorted heating coils or short-stabbed pipe ends.



A record of each fusion attempted is stored in the control box memory and can be viewed on the display or downloaded via a USB connection. The record contains information about the fitting that was fused, the prescribed fusion parameters, the ambient temperature conditions at the time of fusion, GPS location, fusion operator details, fusion cycle termination reasons, and ASTM F2897 tracking and traceability codes for the pipe and fitting.

The control box will terminate a fusion process when any defined protocol is out of range and will display an error message. A list of error message definitions is affixed to the unit for reference if an error occurs.

When using the fitting barcode, the control box checks the ambient air temperature and automatically adjusts the fusion time for that temperature if the fitting barcode requires it.

✓ Adjustment of the fusion time for higher or lower ambient temperature is referred to as “temperature compensation”. Not all fittings require temperature compensation, but all barcodes contain two characters that define whether the feature is used or not. Fittings that require temperature compensation do not contain a resistor pin and have no fusion voltage or time printed on the label. The fusion voltage and time are replaced by “TC”. **For fittings with TC (no fusion time) on the label, always use the barcode supplied with the fitting.**

✓ Let the control box acclimate to the jobsite weather conditions for a minimum period of 15 minutes to ensure that it accurately measures the ambient temperature before beginning the fusion process.

Control box fusion cable tips can be changed or adapted to fit the size of the connecting pins on the electrofusion fitting. Standard GFPC fittings utilize 4.7mm connections.

GFPC AC powered control boxes should receive regular calibration every 2 years to ensure that all monitored parameters are measured accurately and the control box is functioning normally. Units that are past their calibration interval will alert the operator at power-up that maintenance is due, but will continue to function when acknowledged by the operator pressing the green “Start/OK” button.

Power Requirements

Control boxes are available in 115v or 230v versions and have power cable connections that are appropriately sized for the maximum current usage from a generator or inverter. Table 4 provides minimum power requirements by fitting type and size. The power cable connectors should not be replaced with any lower-rated components.

The control box monitors the energy input from the power source to ensure that fluctuations from the generator are within the operating range and alerts the installer when parameters fall out of range. The control box is tolerant to small fluctuations in input voltage or frequency; however not all generators or inverters are equal. When an electrofusion assembly is known to have been installed correctly and there is an error during the fusion cycle, the cause can often be traced to the power supply. It is important to ensure that the power supply is in good working order, has enough fuel to operate for the intended fusion time, and is capable of supplying the required energy for the fitting being fused.

INPUT POWER REQUIREMENTS					
FITTING TYPE	FITTING SIZE	GENERATOR MINIMUM (WATT)	BREAKER MINIMUM 115v / 240v	EXTENSION CORD 25 ft.	EXTENSION CORD 50 ft.
COUPLING	1/2" to 8"	3500	15 / 15 AMP	#10/3	#8/3
COUPLING	10" to 12"	6000	30 / 20 AMP	#10/3*	#8/3*
SADDLE	ALL	3500	15 / 15 AMP	#10/3	#8/3

Table 5- Power requirements

- ⊘ Do not start or stop the generator while the control box is plugged in.
- ⚠ Extension cords can be used; however the wire gauge should not be less than that shown in Table 4 for the maximum length indicated. Length of the extension cord affects voltage drop. Voltage drop is a result of the friction or resistance that electricity experiences flowing through a long wire. Use the shortest extension cord possible.
- ⚠ CAUTION: The rated capacity of a generator is typically less than the peak generator capacity; use the lower of the two stated capacities to determine suitability for use. Capacity can be further reduced by the age and condition of the generator. The generator governor control (also referred to as “economy switch” and “auto-throttle”) must be turned off and the generator should be running at full speed before the fusion begins to provide constant generator electrical output. Users should verify/qualify the output of generator as needed to ensure it functioning correctly. Verification of the performance of generators can be accomplished by the use of test sets such as: http://www.sotcher.com/Load_Bank_Generator_Test_Sets

Fusion Parameters

GFCP control boxes can be operated by four different parameter input methods:

- Auto ID – This method reads a resistor embedded in one of the terminal pins of most GFCP fittings. The cable lead with the red banding indicates the resistor pin reader. GFCP control boxes read the resistor and automatically sets the fusion parameters for that fitting.
- Barcode scanner – The fusion barcode supplied with each fitting contains the fusion parameters needed to fuse the fitting. Scanning the barcode identifies the fitting to the control box and sets the fusion parameters for that fitting, including temperature compensation variables.
- Manual Barcode Entry – Each barcode is comprised of 24 digits. The 24 digits are printed below the barcode. In the event that the barcode cannot be scanned, the 24 digits can be manually entered into the control box via the touch pad.
- Manual Time and Voltage Entry – If known, the fusion voltage and fusion time (in seconds) can be manually entered for the fitting.

Note: All fittings also contain a 16 character ASTM F2897 tracking and traceability barcode. This barcode is a different format than the fusion parameter barcode and **will not be accepted** by the control box by either scanning or manual character entry methods **while the control box is in fusion parameter input sequence**. Traceability code input sequence, if enabled on the control box, will prompt the installer when to scan the ASTM F2897 barcode.

Barcode Scanning:

Barcodes should be kept clean and as flat as possible.

Barcode Wands – These devices are handheld “pens” with a light source at the tip. The wand/pen should be held at a 10° to 30° angle against the barcode. Place the wand/pen against the barcode starting in the white area on one side and scan across the barcode in a fluid motion ending in the white area on the opposite side. The control box will beep when the barcode has been accepted.

Barcode Scanners – These devices are handheld imagers with a trigger. When ready to scan a code, squeeze the trigger. The scanner will emit a circular red light onto the barcode to aid in aiming. Once the barcode is accepted, the light will turn green and the control box will beep.



Barcode Wand



Barcode Scanner

Installation Training Procedures

Electrofusion Coupling Installation Procedure

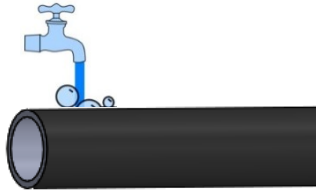
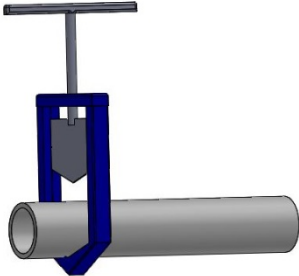
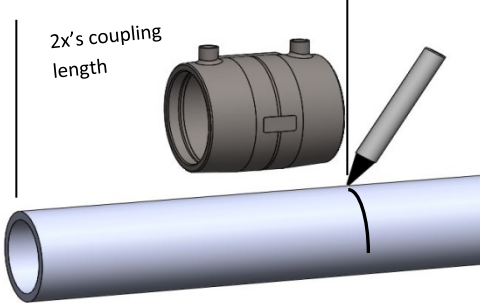
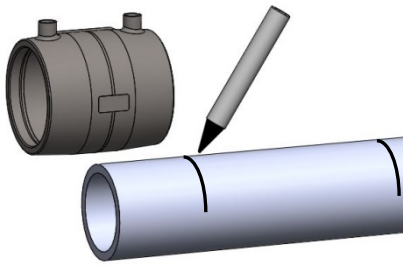
- 1. Wash the pipe ends to remove mud, dirt, or other foreign material.** Refer to the “Cleaning” section of this manual for more details. For this initial cleaning, an area two to three times the length of the electrofusion coupling should be marked and cleaned on each pipe end. Water and a clean cloth can be used for this step. **Dry the pipe and inspect** for and remove any embedded material on the pipe surface.
- 2. Cut the pipe ends squarely.** Pipe cutters are preferred. If using saws or hand tools, refer to Table 2 – Pipe Cut Angle of this manual for the maximum allowable measured cut angle of the pipe end that is allowed for the pipe size being fused.
- 3. A mark should be made on the pipe that is at least twice as long as a full coupling length** from the pipe end. This mark is to indicate a cleaned pipe surface length limit that should not be exceeded when wiping with alcohol in later steps. This step is to prevent the wipe from contacting uncleaned pipe surfaces and potentially spreading contaminants onto cleaned pipe surfaces. **Clean this area with Isopropyl alcohol, wiping in only one direction, and not exceeding the boundary of the area that has been marked. Allow the pipe to dry. Discard the wipe and do not re-use.**
- 4. Using a tape measure or the bagged fitting as a reference, make a second mark slightly more than 1/2 the length of the coupling** to be installed. This mark is to indicate the scrape/peel length needed to ensure that at only peeled/scraped pipe will contact the coupling inside surfaces when properly inserted. It is a good practice to scrape/peel a little more length than needed as visual evidence of pipe preparation for inspection purposes after the pipe has been inserted into the coupling. Note: If a coupling is to be pushed completely over the pipe on one side, the entire length of the coupling should be peeled/scraped on that pipe end.

5. **Scribe** witness marks (see “Scraping/Peeling” section of this manual) onto the pipe surface, or alternately, **mark the area** to be scraped/peeled in a criss-cross pattern.



6. **Scrape/peel the pipe to remove the surface layer** and expose clean virgin pipe material beneath. Break shavings or guide them away as needed to prevent them wrapping around the scraped/peeled pipe surface.

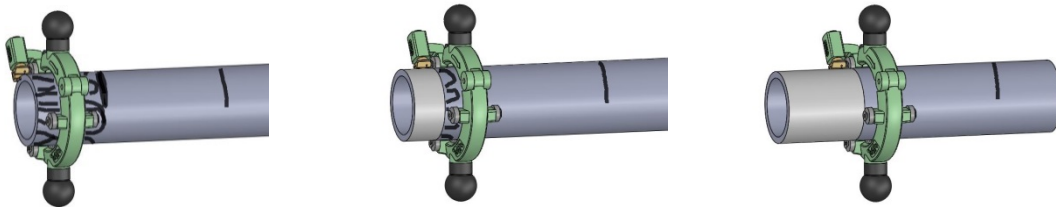

7. **Inspect the scraped/peeled pipe surface thoroughly** to ensure that all marks are removed and that only virgin pipe surface is exposed. **Re-mark the stab depth** at $\frac{1}{2}$ the coupling length onto the pipe end. This mark serves as a visual indicator that the pipe end has been fully inserted to the coupling center.

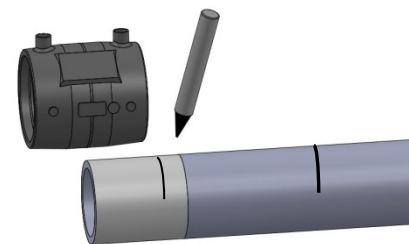

8. **Insert the pipe ends into the coupling to the stab depth marks. Secure the pipe and fitting assembly in an alignment clamp.**

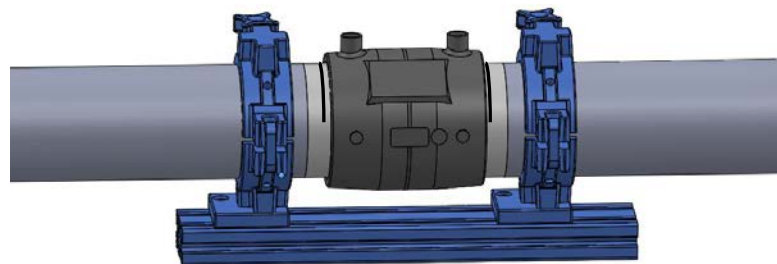

9. **Connect the control box leads to the fitting, verify proper fusion time and voltage is displayed by the control box, and fuse the joint.** Do not leave a fusion unattended.
10. After the fusion cycle is complete, **do not move or disturb the joint for the minimum cooling time displayed by the control box.** The control box can be disconnected from the fitting at this time. Mark the time of day when the clamp can be removed. Mark the joint location with any other information required by the pipeline owner.
11. **Pressure test and backfill only after the required minimum cooling time** for the fitting used has been reached (see Cooling section of this manual).

Electrofusion Saddle Installation Procedure

1. Locate the area on the pipe where the saddle will be applied. **Clean pipe to remove mud, dirt, or other foreign material.** Refer to the “Cleaning” section of this manual for more details. For this initial cleaning, an area at least three times the width of the electrofusion saddle should be cleaned and marked. Water and a clean cloth can be used for this step. Dry the pipe and inspect for and remove any embedded material on the pipe surface.
 - a. **Make a mark on the pipe that is at least 3 times the width of the saddle base, with the intended fusion location centered between the marks.** These marks are to indicate a cleaned pipe surface length limit that should not be exceeded when wiping with alcohol in later steps. This is necessary to prevent the wipe from inadvertently contacting uncleaned pipe surfaces and potentially spreading contaminants onto pipe surfaces that were already cleaned. **Clean this area with Isopropyl alcohol, wiping in only one direction, and not exceeding the area that has been marked. Allow the pipe to dry. Discard the wipe and do not re-use.**

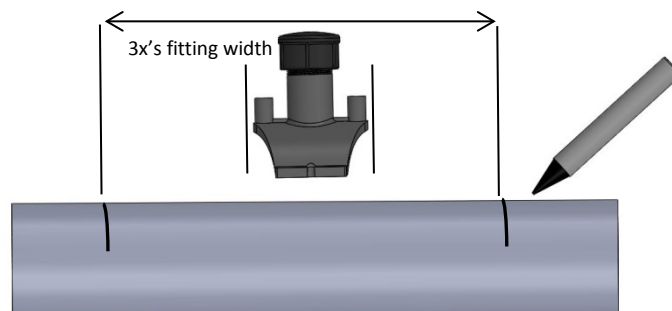

- b. **Make a second set of marks slightly more than the width of the saddle to be installed.** This mark is to indicate the scrape/peel length needed to ensure that at only peeled/scraped pipe will contact the saddle fusion surface. It is good practice to scrape/peel a little more length than needed as visual evidence outside of the fusion area that proper preparation has taken place.

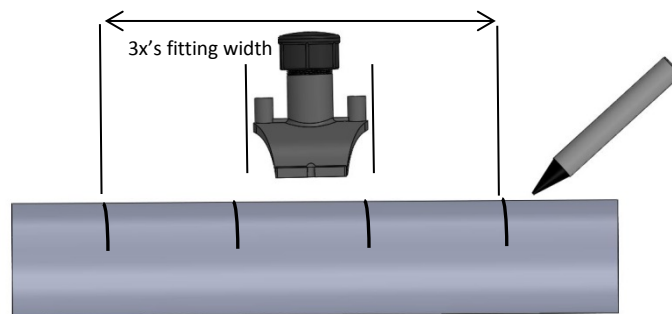

2. **Scribe witness marks** (see “Scraping/Peeling” section of this manual) **onto the pipe surface, or alternately, mark the area to be scraped/peeled in a criss-cross pattern.**

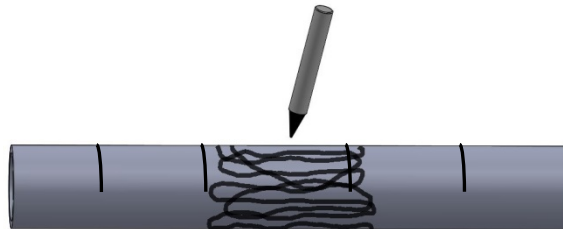

3. **Scrape/peel the pipe to remove the surface layer and expose clean virgin pipe beneath.**

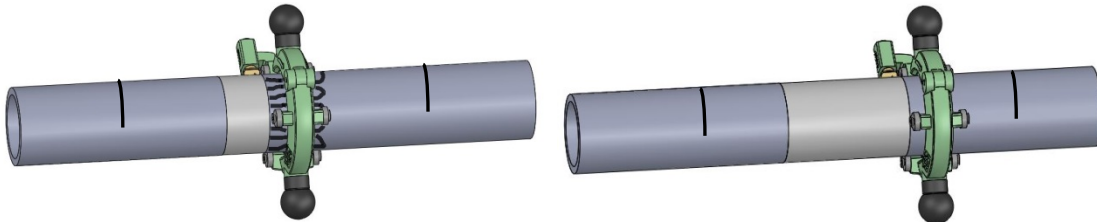

4. **Inspect the scraped/peeled pipe surface thoroughly** to ensure that all marks are removed and that only virgin pipe surface is exposed. **Remove the saddle from the bag and place onto the scraped/peeled pipe surface.** Secure the pipe and saddle fitting assembly by clamping to the pipe with the appropriate clamping device.

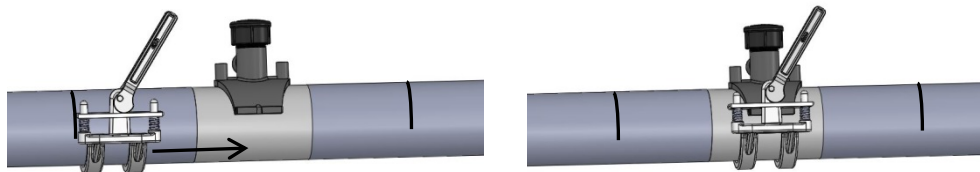

5. **Connect the control box leads to the fitting, verify proper fusion time and voltage is displayed by the control box, and fuse the joint.** Do not leave a fusion in progress unattended.
6. After the fusion cycle is complete **do not move or disturb the joint for the minimum cooling time displayed by the control box.** Mark the time of day when the clamp can be removed. Mark the joint location with any other information required by the pipeline owner.
7. **Pressure test, tap, and backfill only after the required minimum cooling time** for the fitting has elapsed (see “Cooling” section of this manual).

Re-Fusion

In the event that a fusion cycle does not complete, and is not due to incorrect assembly or a fitting fault, it may be necessary to re-fuse (restart) a fusion cycle.

 Consult your company's (or the pipeline owner's) O&M guidance to determine if re-starting a fusion is allowed. If prohibited, follow the O&M guidance.

Only under circumstances of an **input power interruption** can a fitting can be re-fused. These events are typically associated with generator power loss to the control box or fusion cables being inadvertently disconnected from the fitting during the fusion cycle. Fittings that fault for any other termination causes should be removed or abandoned and replaced with a new fitting.

Procedure:

1. **Allow the fitting and pipe assembly to cool completely** to ambient temperature. This cooling period is dependent upon the size and style of the fitting and may take up to several hours. It is important to note that immediately after a fusion attempt that heat may not transfer to the fitting surface so it may feel cool to the touch. Wait several minutes after a fusion interruption before checking the fitting temperature to allow internal heat to migrate to the fitting surface.
2. **Verify** with a pyrometer that the fitting and surrounding pipe temperature have equalized with the pipe temperature at least two feet away from the fitting.
3. **Re-start the fusion and fuse for the entire fusion cycle** prescribed for the fitting. Do not attempt to subtract time based on the first fusion attempt

Tapping

Electrofusion tapping tees can be tapped after sufficiently cooled on pressurized pipe. The tapping tee contains a cutter (punch) that can be threaded downward by removing the cap and using the appropriate tapping tool until it pierces the main pipe. The tapping tool has stop indicators that provide a maximum cutter depth. The cutter retains the pipe coupon and is then retracted to its final service position at the top of the tapping tee chimney. **DO NOT REMOVE THE CUTTER FROM THE TAPPING TEE.** For a service tee (1 IPS or smaller outlet) the cutter should be positioned flush with the top of the fitting chimney. For a high volume tapping tee (1 ¼ or 2 IPS outlet), the cutter should be positioned in contact with the upper o-ring seal as described in the following instruction. **Replace the cap by hand tightening only.**

- ✔ Cap o-rings are only lightly coated with a dry film lubricant during manufacture to prevent possible contamination of the fusion surface. Additional lubrication of the cap O-rings after the fusion process has taken place is an acceptable practice and can be beneficial in achieving the initial seal. Parker O-Lube®, Parker Super-O-Lube® (884), or equivalent, are recommended for this purpose.
- ✘ Do not tighten threaded caps with a wrench. Wrenches can cause overtightening and long-term failure of the plastic threads. **Hand tighten only!**
- ✘ Do not exceed the maximum cutter depth of the tapping tool stop. The cutter can bottom out and strip fitting threads.
- ✘ Do not use power tools to tap. Excessive heat from friction can melt or strip fitting threads.
- ⚠ **DANGER!** Do not remove the self-tapping cutter from the fitting. Personal injury or pipeline media release may result if the cutter is removed while the system is pressurized.
- ⚠ Follow all safety rules and protocols for grounding and static discharge when working in a flammable gaseous environment.

Service Tapping Tee:

1. Remove cap to expose punch.

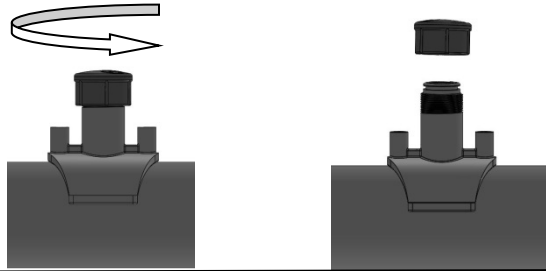

2. Insert tapping tool into punch.

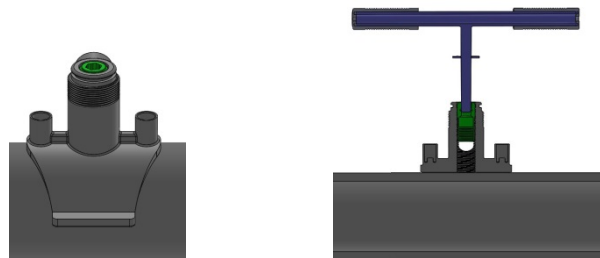

3. Rotate tapping tool **clockwise** until the stop is reached. Apply even turning force on handles and avoid side-to-side pressure. Do not continue to turn the punch after the stop has been reached.

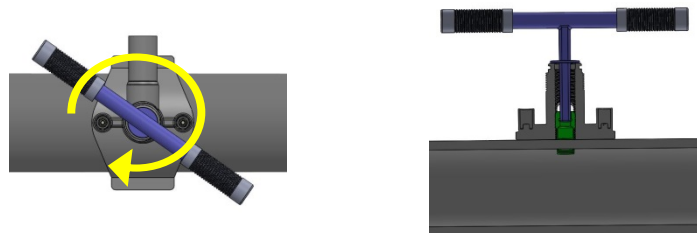

4. Back punch upward by rotating **counter-clockwise** until the punch is flush with the top of the fitting chimney. **STOP! DO NOT REMOVE PUNCH FROM CHIMNEY!**

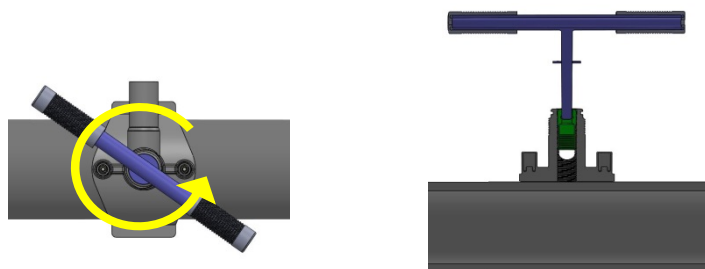

5. Remove tapping tool. Lubricate cap and chimney o-rings if needed and replace cap. Tighten cap hand tight only, do not use wrenches. Check for leaks per normal procedures.

High Volume Tapping Tee:

1. **Inspect the tapping tool** to ensure that parts move freely and are not damaged. Inspect the seal head to **ensure that the O-ring is in place** and in good condition. This O-ring must be in place and sealed at all times or the punch seal O-ring will be displaced and will not seal in the final steps. (If the seal head O-ring is missing, the O-ring from the fitting cap is the same size and can be used during tapping.)

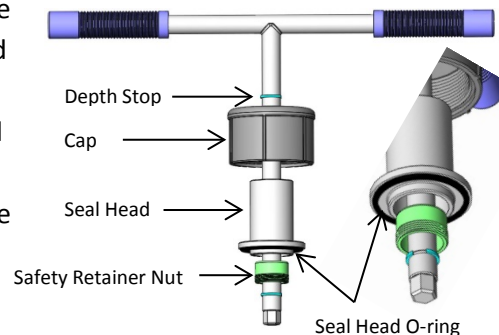

2. Once the fusion is completed, adequately cooled, and pressure tested, **remove the cap** to expose the tapping tee punch.

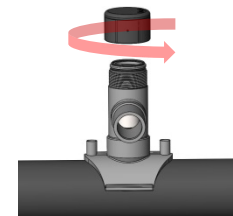

3. The punch is located in the center of the outlet bore at the factory to allow for unrestricted flow during pressure testing. It must be moved to the top of the fitting, using the tapping tool hex wrench. **Rotate the punch counter-clockwise** until it is firmly seated against the O-ring inside the tapping tee. Use care not to pinch or deform the O-ring.

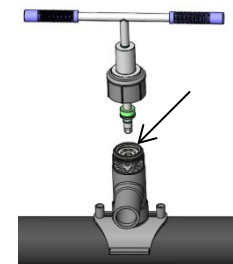

4. **Install the safety retainer nut** from the tapping tool into the threads on the top of the punch.

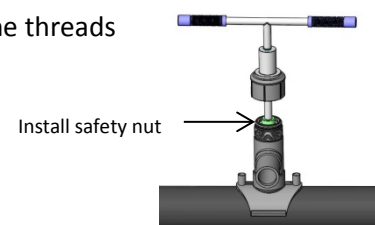

5. **Slide the seal head and cap down and thread the cap onto the fitting. Tighten the cap firmly by hand.** A **reference mark** can be made on the tapping tool shaft at this time that indicates when the cutter has returned to its position against the O-ring after the tapping operation has been completed.

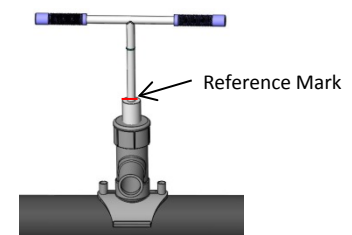

6. **Rotate tapping tool clockwise** until it contacts the depth stop ring. **Re-tighten the cap** as needed after the first several revolutions and make sure the cap remains tight throughout the tapping process. If at any time gas is heard escaping through the cap, **retighten the cap**. Once the depth stop has been reached the punch is at its maximum depth and the main has been tapped.

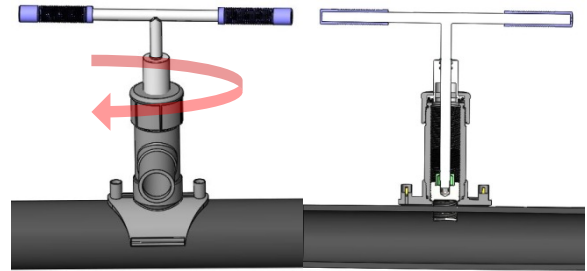

7. **Rotate the tapping tool counter-clockwise** to raise the cutter back to the top of the fitting. Continue to check cap to ensure that it is tight as the cutter is raised. Rotate until the tool **reaches the stop or until the reference mark** made in step 5 is visible. Remove the tapping tool. **Inspect the O-ring seal** against the punch to make sure it is in place and sealed.

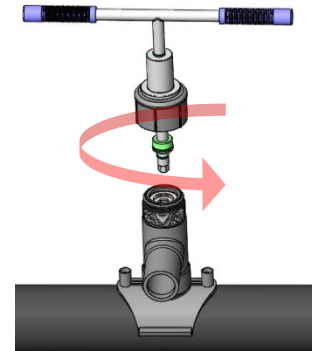

8. **Replace the tapping tee cap and hand tighten.** Do not use wrenches. Check for leaks per normal procedure.

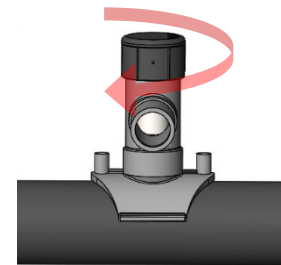

- ⚠ Notice: Attempts to seal the cutter against the internal O-ring while under pressure will fail if the seal head O-ring is missing or the seal head is leaking (even a small amount) when the punch makes initial contact with the O-ring. The O-ring will extrude out of the groove and become pinched between the punch and fitting chimney if any leakage is present. To correct a pinched O-ring, back the punch down until the O-ring can be reset into the groove, re-install the seal head, then return the punch to contact with the O-ring.



O-ring properly seated against punch



O-ring pinched and displaced

Pressure Testing

Hydrostatic Pressure testing can be conducted in accordance with the recommendations of the pipe manufacturer or as described in ASTM F2164 STANDARD PRACTICE FOR FIELD LEAK TESTING OF POLYETHYLENE (PE) PRESSURE PIPING SYSTEMS USING HYDROSTATIC PRESSURE, typically 1.5 x's the rated working pressure not exceeding 8 hours in duration for a single test.

Pneumatic pressure tests can be conducted in accordance with the recommendations of the pipe manufacturer, or as described in ASTM F2786 - STANDARD PRACTICE FOR FIELD LEAK TESTING OF POLYETHYLENE (PE) PRESSURE PIPING SYSTEMS USING GASEOUS TESTING MEDIA UNDER PRESSURE (PNEUMATIC LEAK TESTING).

- ⚠ DANGER! If conducting pneumatic tests with gaseous media, understand and take appropriate safety measures and exercise caution due to the potential for sudden release of stored energy of compressed gases.

Operator Training Qualification Guide

Georg Fischer Central Plastics, LLC strongly recommends that electrofusion fittings should be installed only by persons that have received training from an authorized instructor, and have a strong working knowledge of polyethylene and heat fusion, and have qualified electrofusion joints through destructive testing.

Persons responsible for the joining of polyethylene pipes used in Department Of Transportation regulated gas distribution by fusion methods must qualify according to the requirements of Title 49 Code of Federal Regulations, Section 192.285. Persons responsible for joining of polyethylene pipes used in municipal potable water, wastewater, or industrial piping applications may be subject to other qualification requirements at a local or project level.

Recommended Training Curriculum

Georg Fischer Central Plastics recommends that persons that make electrofusion joints should qualify to a joining procedure through personal classroom instruction, witnessed application of instructed procedures while making test fusions, and qualification of test fusions through destructive tests. Qualification should take place using electrofusion couplers (sockets) and saddles (sidewall) independently in order to qualify for both socket and sidewall electrofusion methods.

Qualification size range:

- ⚠ Coupling: Qualifications using 2 IPS or larger sockets qualifies the installer for all sizes of sockets through 12 IPS. Qualification using 16 IPS or larger qualifies the installer for socket sizes from 14 IPS to 26 IPS (requires meeting requirements of GFCP Large Diameter Training course).
- ⚠ Saddle: Qualifications using 2 IPS or larger saddles qualifies the installer for all sizes 1 ¼ IPS through 12 DIPS. Qualification using 14 IPS or larger saddles qualifies the installer for all sizes 14 IPS through 48 IPS.

The frequency of re-qualification may be defined by the pipeline operator or regulatory code. GFCP recommends as best practice that any installer that has not performed a fusion joint within the last 12 months should requalify through a minimum of visual examination and destructive testing before attempting fusions that will be put into service. Failure of any fusion that has been placed into service should be examined and, if found to have been caused by installer procedural error, shall require re-qualification of that installer.

Destructive Tests

The destructive tests to qualify a fusion joint and joiner are described in section 9 of ASTM F1055. The tests for a coupling (socket) joiner are any one or more of the following:

- Minimum Hydraulic Burst Pressure Test
- Sustained Pressure Test
- Tensile Strength Test
- Joint Integrity Test (Crush test)

The destructive tests to qualify a saddle (sidewall) joiner are any one or more of the following:

- Minimum Hydraulic Burst Pressure Test
- Sustained Pressure Test
- Impact Test (ASTM F905)
- Joint Integrity Test (Crush test)

Passing results for visual inspection and any one of the above tests on specimen joints for couplings and saddles qualifies the installer to the requirements of Part 192.285.

Couplings (Sockets)

The pipe and fitting specimen should be cut and subjected to joint evaluation tests. Bend tests, peel tests, and crush tests are helpful in locating fusion weaknesses.

To prepare a specimen for crush testing, it is necessary to cut the pipe and coupling longitudinally in half as near to the centerline of the pipe and coupling as possible as shown in the image to the right. It is desirable to leave at least 3"(75mm) of pipe length for 2 inch and smaller diameter pipes and 8"(125mm) of pipe length for up to 12 inch diameter pipes at each end of the coupler for gripping by the vise/press.

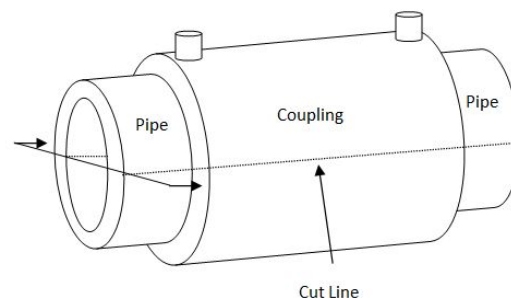

Crush Test Cut

Place a specimen half in a vise or press so that the outermost wire of the fusion zone is approximately 1 1/4" (32mm) from the vise jaws . **Close the vise jaws until the pipe walls meet.** Repeat this process for each end of both halves of the coupling.

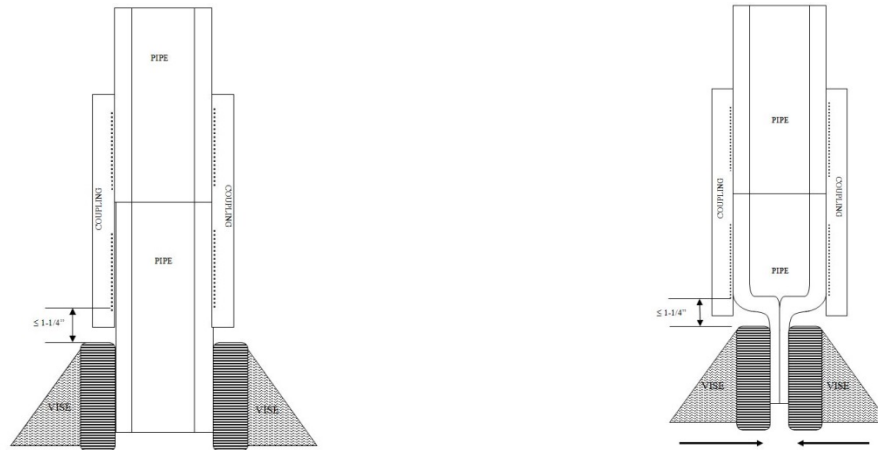

Inspect the crushed specimens for separation of the pipe and fitting in the fusion zone. Some minor separation at the fusion interface (up to 15%) may be seen at the outermost region of the fusion zone, this does not constitute failure. Ductile failure of the pipe, fitting, or PE insulation around the wires is acceptable. **There should be no separation at the fusion interface of the pipe and fitting beyond the 15% at the outer most edges.** Refer to the images in the Destructive Test Results section of this manual for examples of passing and failing results.

Saddles (Sidewall)

Tapping tees should be left intact for crush testing. Pipe lengths can be cut to the edges of the fitting base. Place the pipe and fitting into a vise so that the jaws are within 1/2" (13mm) of the bottom of the saddle. **Close the vise until the inner pipe walls meet.**

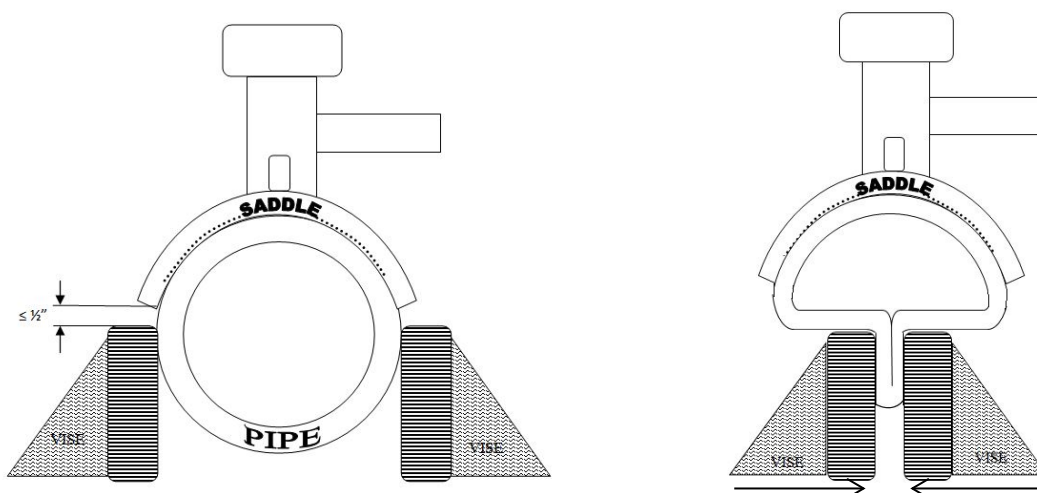

Inspect the crushed specimens for separation of the pipe and fitting in the fusion zone. Some minor separation (up to 15%) may be seen at the outermost region of the fusion zone, this does not constitute failure. Ductile failure of the pipe, fitting, or PE insulation around the wires is acceptable. **There should be no separation at the fusion interface of the pipe and fitting beyond the 15% at the outermost edges.** Refer to the images in the Destructive Test Results section of this manual for examples of passing and failing results.

FET Test (ASTM F1055 9.4.3): **Slit the socket or saddle into four sections** as illustrated below. If desired, radially cut the socket in half along the centerline of the joint. Pipe extending from fittings may be cut back to about 1 in. from the fitting edges.

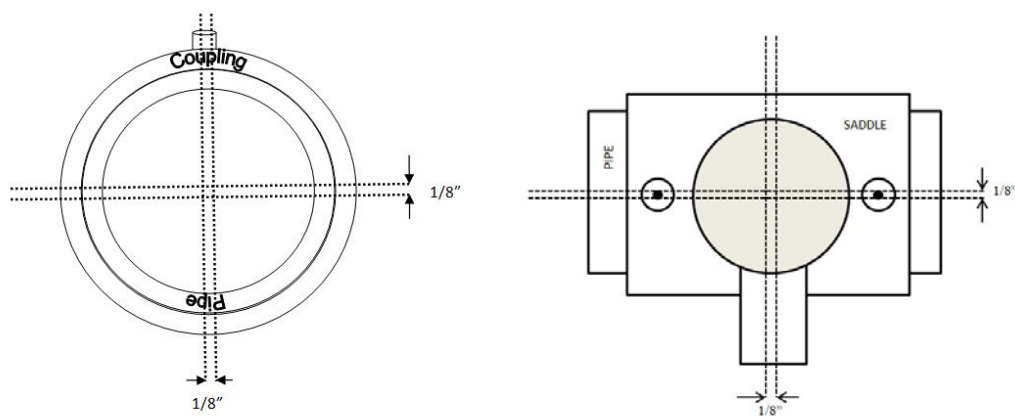

Cut FET specimens approximately **1/16 to 1/8 inches wide** from each fusion or joint half. A **minimum of four FET strips** shall be cut from each end of the socket and from the saddle spaced approximately 90° apart:

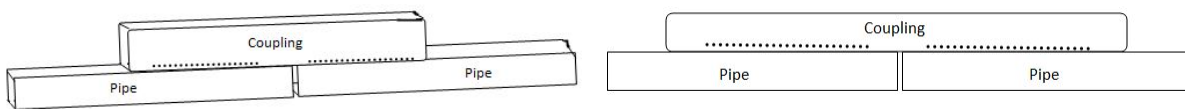

Coupling/Socket specimens- 4 from each socket end at 90 degree intervals x 1/8" wide.

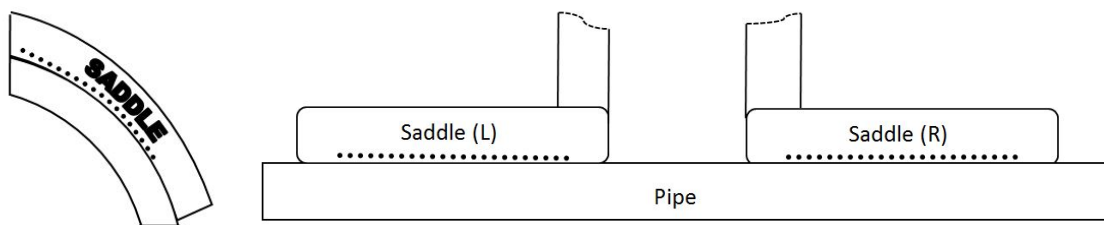

Saddle Specimens – 4 total, 2 radial from each side, 2 axial from each side at 90 degree intervals x 1/8" wide.

Grip the FET specimen in a vise or clamping device so that the bond line between the pipe and fitting is at least 1/16 in. from the edges of the vise jaws. **Flex the specimen four times 90° in both directions** so that the bending moment is applied directly along the length of the fusion interface bond line. For small specimens pliers may be used in lieu of a vise as long as the entire length of the fusion is flexed.

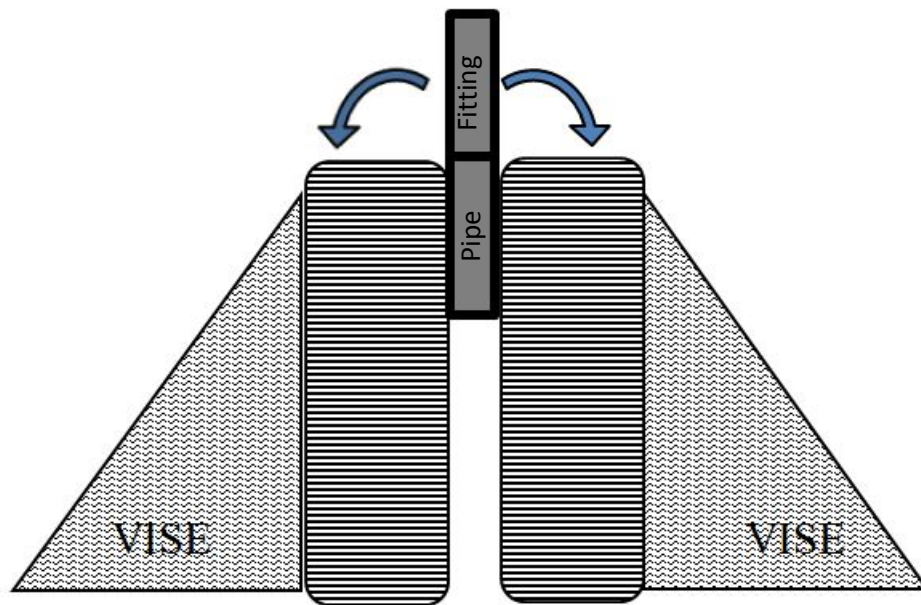

Separation of the specimen along the bond line constitutes failure of the specimen. Some minor separation at the outer limits of the fusion heat source may be seen or there may be voids between wires. This does not constitute failure as long as the void does not exceed 10% of the total fusion length, or in the case of multiple voids, 20% of the total fusion length when combined. Ductile failure in the pipe, fitting, or the wire insulation material is acceptable as long as the bond interface remains intact. Refer to the images in the Destructive Test Results section of this manual for examples of passing and failing results.

Images of Acceptable and Unacceptable Destructive Test Results



Coupling Crush Test - Passing Result

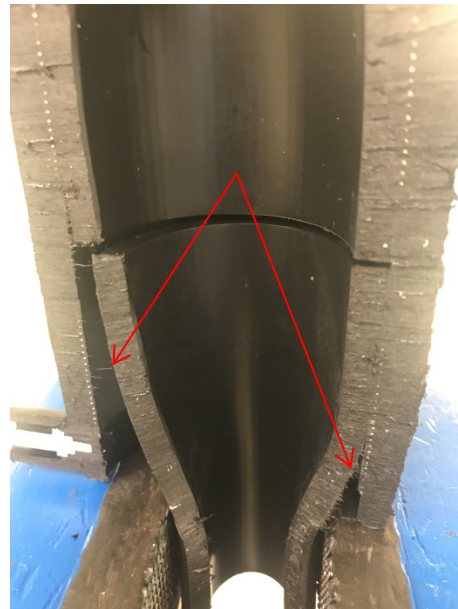

Coupling Crush Test - Failing Result



Saddle Crush Test – Passing Result

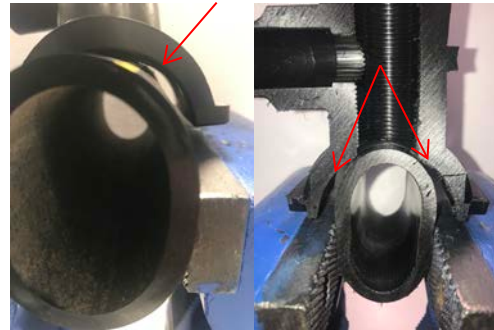

Saddle Crush Test – Failing Result



FET Test – Passing Result



FET Test – Failing Result

Electrofusion Fitting Pressure Rating, Testing, and Specifications

Electrofusion fittings are qualified for various uses including regulated natural gas distribution, potable water, fire suppression systems, chemical pipe and waste, and industrial piping.

Applicable Performance Standards:

ASTM D2513	Standard Specification for Polyethylene (PE) Gas Pressure Pipe, Tubing, and Fittings
ASTM F1055	Specification for Electrofusion Type Polyethylene Fittings for Outside Diameter Controlled Polyethylene and Crosslinked Polyethylene (PEX) Pipe and Tubing.
ASTM D3350	Specification for Polyethylene Plastic Pipes and Fittings Materials
AWWA C906	Standard for Polyethylene Pressure Pipe and Fittings 4in through 63 inch for Water Distribution

Certifications:

ANSI/NSF 61	Standard for Drinking Water System Components and Health Effects
FM 1613	Approval Standard: Plastic Pipe and Fittings for Underground Fire Protection Service
CSA B137.4.1	Polyethylene Piping Systems for Gas Service

Compatible Pipe Standards:

ASTM D2737	Specification for Polyethylene (PE) Plastic Tubing
ASTM D3035	Standard for Polyethylene (PE) Plastic Pipe (DR-PR) Based on Controlled Outside Diameter
ASTM F714	Specification for Polyethylene (PE) Plastic Pipe (DR-PR) Based on Outside Diameter
ASTM F876	Specification for Crosslinked Polyethylene (PEX) Tubing
ASTM F2623	Specification for Polyethylene of Raised Temperature (PE-RT) SDR 9 Tubing
ASTM F2788	Specification for Metric and Inch-sized Crosslinked Polyethylene (PEX) Pipe
ASTM F2769	Specification for Polyethylene of Raised Temperature (PE-RT) Plastic Hot and Cold Water Tubing and Distribution Systems

PE Resin:

PE4710	Pre-blended black high density virgin resin. Recognized by the Plastic Pipe Institute as having a PE3408 / PE4710 / PE100 rating and a Hydrostatic Design Basis of 1600 psi @ 73°F. This resin has a cell classification of 445574C in accordance with ASTM D3350 and is listed in PPI TR-4.
PE2708	Pre-blended medium density virgin resin. Recognized by the Plastic Pipe Institute as having a PE2406 / PE2708 rating with a Hydrostatic Design Basis of 1250 psi @ 73°F. This resin has a cell classification of 234373E in accordance with ASTM D3350 and is listed in PPI TR-4.

Pressure Rating:

Pressure ratings depend on the end-use application and governing design factors for a particular application such as regulated gas distribution systems under the jurisdiction of CFR Part 192 or potable water systems designed to AWWA C906. These design factors result in different pressure ratings for polyethylene piping systems of the same design, but different end-uses. Contact GFPC for specific pressure ratings based on the end-use application.

Pressure Testing:

Pressure testing can be conducted in accordance with the recommendations of the pipe manufacturer, or as described in ASTM F2164 *STANDARD PRACTICE FOR FIELD LEAK TESTING OF POLYETHYLENE (PE) PRESSURE PIPING SYSTEMS USING HYDROSTATIC PRESSURE*, typically 1.5 x's the rated working pressure not exceeding 8 hours in duration for a single test.

Maximum Operating Temperature:

The maximum operating temperature of polyethylene is 140°F. Pressure de-rating factors should be considered when operating systems above the 73°F stated pressure rating, to maintain the 50 year substantiated long-term hydrostatic strength of the polyethylene material.

Chemical Resistance:

Polyethylene generally exhibits strong resistance to many chemical compounds. Known chemical resistance characteristics at specified temperatures can be found in PPI Technical Report TR-19.

Storage/Shelf Life:

Black electrofusion fitting resin contains a 2% to 3% carbon black additive to protect against UV degradation effects. Yellow electrofusion fitting resin contains a stabilization pack that also provides some degree of protection against UV effects. These protections do not prevent oxidation of fusion surfaces when exposed to UV sources during storage. Fittings should not be removed from their original packaging until use. Fittings stored indoors in their original packaging have a virtually unlimited shelf life.

Electrofusion fittings are packaged in sealed plastic bags as protection against accumulation of dust, dirt, and contamination. The bag should remain in place during normal handling and should only be removed at the time of installation. Bags are not airtight, and in many cases have holes made to allow trapped air to escape. Small dust particles or moisture from humidity may enter the bag and can be removed from the fitting with isopropyl alcohol at the time of installation. Electrofusion fittings are also packaged in boxes to protect against other sources of degradation, such as oxidation due to UV exposure over long periods of storage. Fittings should always be stored indoors, in their original packaging, until the time of installation.

ⁱ Previous versions of GFCP installation manuals included a minimum of 70% isopropyl alcohol with no additional additives except water. 70% isopropyl alcohol was accepted as the minimum concentration because it was historically more commonly available than higher concentrations. The use of 70% isopropyl alcohol as an alternate will not affect the fusion joint quality and has been extensively qualified, however it may not be as effective as a cleaning agent as higher concentrations and can take longer to dry in colder climates.